



Chapter 4

Transportation

TABLE OF CONTENTS

CHAPTER 4	TRANSPORTATION.....	1
INTRODUCTION		1
4	PURPOSE.....	1
4.1	Performance Outcomes	1
4.1.1	Performance Outcomes - Detail	2
4.1.2	Creating Good Infrastructure – Design-Led Approach.....	2
4.2	Referenced Documents.....	3
4.2.1	Resource Management Plan Requirements	3
4.2.2	Document and Standards.....	3
4.2.3	Transport Network	5
	STANDARDS	5
4.3	Design Process	5
	Mandatory Matters	5
4.3.1	General	5
	Good Practice	7
4.3.2	General	7
4.4	Network Layout Form and Function Design	7
	Mandatory Matters	7
4.4.1	Road Hierarchy.....	7
4.4.2	Design within the Hierarchy.....	10
4.4.3	Minimum Intersection Spacing	11
4.4.4	Connectivity	12
4.4.5	Pedestrian, Cyclist and Public Transportation.....	14
4.4.6	Structures	14
4.4.7	Commercial Zone Design	14
	Good Practice	15
4.4.8	Layout.....	15
4.4.9	Pedestrian, Cyclist and Public Transport Considerations	15
4.4.10	Intersections	16
4.4.11	Design for Larger Vehicles	16
4.4.12	Use of Residential Lanes.....	17
4.5	Design for the Speed Environment.....	17
	Mandatory Matters	17
4.5.1	Design for Target Speed	17
4.5.2	Traffic Calming Devices.....	18
	Good Practice	18
4.5.3	Speed Environment.....	18
4.5.4	Speed Reduction Measures	19
4.6	Transport Cross-Sections.....	20
	Mandatory Matters	20
4.6.1	General	20
4.6.2	Shoulder Design	23
4.6.3	Flush Medians	23

4.6.4	Turning Area Design.....	23
4.6.5	Staged Road Construction Ends	24
4.6.6	Service Lanes	24
4.6.7	Services	24
	Good Practice	25
4.6.8	General	25
4.6.9	Legal Road Widths	25
4.6.10	Flush Medians	26
4.6.11	Turning Areas	26
4.6.12	Shoulders.....	26
4.7	Batter Slope, Bridge and Retaining Structure Design	26
	Mandatory Requirements.....	26
4.7.1	Batter Slope	26
4.7.2	Support and Retaining Structures and Bridges	27
4.7.3	Geotechnical Risk Areas	28
4.7.4	Sub-soil Drainage	28
	Good Practice	28
4.7.5	Hillside Construction.....	28
4.7.6	Land Stability	28
4.7.7	Retaining Walls.....	29
4.8	Road Geometry	29
	Mandatory Requirements.....	29
4.8.1	Gradients	29
4.8.2	Crossfall.....	30
4.8.3	Super Elevation	30
4.8.4	Horizontal curves.....	30
4.8.5	Safe Stopping Sight Distances	31
	Good Practice	33
4.8.6	Gradients	33
4.8.7	Super-Elevation	33
4.8.8	Kerb Lines.....	33
4.9	Intersection Design.....	33
	Mandatory Requirements.....	33
4.9.1	General	33
4.9.2	Sight Distances.....	34
4.9.3	Kerb Radii.....	35
	Good Practice	36
4.9.4	General	36
4.9.5	Four Way Intersections.....	36
4.9.6	Roundabouts	36
4.9.7	Traffic Signals.....	37
4.10	Private Access and Crossings	37
	Mandatory Requirements.....	37
4.10.1	General	38
4.10.2	Private Access	38
4.10.3	Gradients	41
4.10.4	Sight Distances (other than Safe Intersection Site Distance)	41
4.10.5	Visibility Splays	42
4.10.6	Tracking Paths.....	43

4.10.7	Minimum distance of a vehicle crossing from intersections	44
	Good Practice	45
4.11	Clear Zones.....	46
	Mandatory Requirements.....	46
4.11.1	General	46
	Good Practice	47
4.11.2	General	47
4.12	Parking (on street/road)	47
	Mandatory Requirements.....	47
4.12.1	General	47
	Good Practice	48
4.13	Public Transport, Footpaths, Public Accessways and Cycle Facilities	50
	Mandatory Matters	50
4.13.1	Safety from Falling.....	50
4.13.2	Public Transport	50
4.13.3	Footpaths.....	50
4.13.4	Crossings for Pedestrians and Cyclists	52
4.13.5	Cycle Facilities.....	53
4.13.6	Public Accessways	53
	Good Practice	54
4.13.7	Public Transport	54
4.13.8	Footpaths.....	54
4.13.9	Cycle Facilities.....	56
4.13.10	Crime Prevention through Environmental Design (CPTED)	57
4.13.11	Intersections and Connectivity.....	58
4.14	Road Marking and Signs	58
	Mandatory Requirements.....	58
4.14.1	Road Marking	58
4.14.2	Signs and Gateway Treatments	58
	Good Practice	59
4.14.3	Road naming	59
4.15	Streetscaping	59
	Mandatory Requirements.....	59
4.15.1	General	59
4.15.2	Grassing	60
4.15.3	Planting.....	60
4.15.4	Street Trees.....	61
4.15.5	Street Furniture.....	62
	Good Practice	62
4.15.6	General	62
4.15.7	Planting and Grassing	62
4.15.8	Street Trees.....	63
4.15.9	Street Furniture.....	63
4.16	Construction General	64
	Mandatory Matters	64
4.16.1	General	64
4.16.2	Road Assessment Maintenance Management (RAMM) Data	64
4.16.3	Earthworks.....	64
4.16.4	Earthworks Routine Testing	65
	Good Practice	66

4.16.5	Land Stability	66
4.16.6	Sedimentation and Erosion Control.....	66
4.17	Structural Design of Pavement.....	66
	Mandatory Matters	66
4.17.1	General	66
4.17.2	Submission of Test and Design Data	67
4.17.3	Basecourse and Sub-basecourse Aggregate.....	67
4.17.4	Acceptance Criteria – Pavement Strength	68
4.17.5	Acceptance Criteria – Road Profile	68
4.17.6	Stabilisation of Construction Courses	69
	Good Practice	69
4.17.7	General	69
4.18	Subgrade.....	69
	Mandatory Matters	69
4.18.1	Subgrade testing	70
4.18.2	Subgrade Drainage	70
	Good Practice	70
4.18.3	Subgrade testing	70
4.19	Carriageway Surfacing	71
	Mandatory Matters	71
4.19.1	General	71
4.19.2	Seal Design	71
4.19.3	Sealing Binder	72
4.19.4	Sealing Chip	72
4.19.5	Ground Sterilising	72
4.19.6	Application of Sealing Binder.....	72
4.19.7	Application of Chip.....	72
4.19.8	Acceptance Criteria	72
4.19.9	Dense Graded Asphalt (Asphaltic Concrete)	73
	Good Practice	73
4.19.10	General	73
4.20	Formation of Residential Lanes, Service Lanes and Private Ways	74
	Mandatory Matters	74
4.20.1	General	74
	Good Practice	75
4.20.2	General	75
4.21	Kerb and Channelling	75
	Mandatory Matters	75
4.21.1	General	75
4.21.2	Benchmarks.....	76
	Good Practice	77
4.21.3	General	77
4.22	Paths	77
	Mandatory Matters	77
4.22.1	General	77
4.22.2	Concrete Paths	77
4.22.3	Asphaltic Concrete Paths	78
4.22.4	Acceptance Criteria	78

APPENDICES

Appendix A Form 1 – RAMM Update Sheet

LIST OF TABLES

Table 4-1	Documents, Standards and References	3
Table 4-2	Road Safety Audit Stage Requirements	6
Table 4-3	Road Hierarchy	8
Table 4-4	Intersection Spacing above 50Km/h	11
Table 4-5	Target Speed Environment	17
Table 4-6	Minimum Provision and Width of Elements for 'Classified Roads'	21
Table 4-7	Minimum Provision and Width of Elements for 'Unclassified Roads'	22
Table 4-8	Maximum Road Gradients	30
Table 4-9	Safe Stopping Sight Distance	31
Table 4-10	Corrections due to Grade - metres	32
Table 4-11	Safe Intersection Sight Distance	34
Table 4-12	Grade corrections to ASD and SISD (cars)	35
Table 4-13	Private Access and Crossing Design	39
Table 4-14	Minimum Sight Distance from Private Vehicle Access Points	42
Table 4-15	Minimum Distance of Vehicle Access from Intersections - metres	44
Table 4-16	Clear Zone Widths (With Kerb)	46
Table 4-17	Critical Aspects of Footpath Design	52
Table 4-18	Primary Characteristics of Walkable Communities	55
Table 4-19	Crossing Facilities	56
Table 4-20	Design Traffic Loading ESA Minimums	67
Table 4-21	Maximum Pavement Deflection	68

LIST OF FIGURES

Figure 4-1	Performance Outcomes	1
Figure 4-2	Inter-relationship of Road Hierarchy	10
Figure 4-3	Minimum Intersection Separation in areas with a regulatory speed of 50km/h or below	12
Figure 4-4	Extent of Cul-de-sac – Not Permitted	13
Figure 4-5	Extent of Cul-de-sacs - Permitted	13
Figure 4-6	Cul-de-sac public accessway connection for active transport	14
Figure 4-7	Hammerhead and Fishtail Turning Head Arrangements	23
Figure 4-8	Measurement of Safe Stopping Sight Distance	32
Figure 4-9	Drive concept gradients for residential private access	41
Figure 4-10	Minimum Visibility Splay	43
Figure 4-11	Visibility Splay for high volume or high safety risk vehicle access points	43
Figure 4-12	Tracking Paths and Access- Steep hillsides only	44
Figure 4-13	Minimum Footpath Widths for Through Width of 1.5m	51

CHAPTER 4 TRANSPORTATION

INTRODUCTION

4 PURPOSE

The purpose of this chapter is to ensure that the region's transportation infrastructure is designed and constructed to meet high standards of urban design, ensuring a safe, efficient and high amenity environment for all users of the transport system.

This transportation chapter is divided into three sections to enable readers to quickly find the most relevant information for their needs:

- a) **Transport Network** - Transport Network illustrates the multitude of functions roads provide for a diverse range of users. It identifies principles for designing a transport network to accommodate the different functions and how to provide for the convenient, safe and efficient movement of various user groups.
- b) **Detailed Design** - Design identifies design principles and specifies parameters for the transport system to achieve the objectives sought from both individual roads and the wider transport network for all user groups. It recognises the importance and value of the transport asset as a public place and environments in which a range of infrastructural services are located.
- c) **Construction** - Construction specifies engineering standards that apply for the construction of particular aspects of transport infrastructure. Appropriate construction standards are essential to ensure that Council's assets are constructed to an appropriate quality. These standards allow for cost-effective and long-term benefits that consider environmental effects and optimise efficiency of Council's ongoing operation and maintenance investment.

4.1 Performance Outcomes

Transportation performance outcomes sought by these standards are far wider than simply providing for the transport service and infrastructure but extend to much broader community outcomes as shown in Figure 4-1 below and the following list in section 4.1.1.

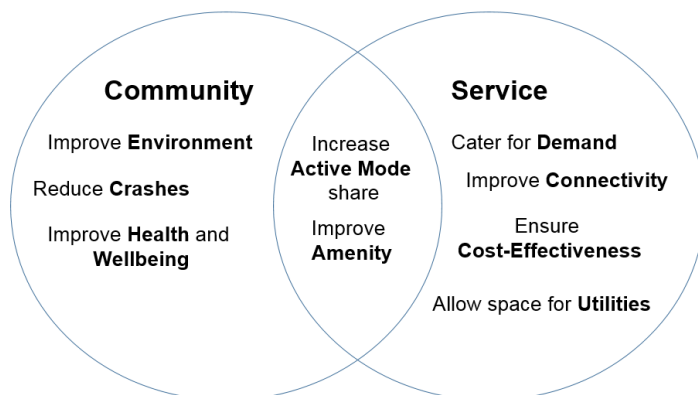

Figure 4-1 Performance Outcomes

4.1.1 Performance Outcomes - Detail

- a) A transportation network that is well connected, convenient and easy to navigate, linking residential housing, commercial and industrial activities, points of attraction, facilities and amenities in an efficient way;
- b) A transportation network that is safe for all users;
- c) A transportation network that supports a range of transportation alternatives to the private motor vehicle, including cycling, walking, mobility scooters and public transport;
- d) Transport corridors that can accommodate a range of functions, including parking, stormwater management, utilities and public spaces;
- e) Transport corridors that provide an attractive, high amenity network that recognises people's appreciation of its pleasantness, aesthetic coherence, and cultural and recreational attributes;
- f) A transportation network that has the capacity to accommodate current and future demand from all users of it;
- g) Networks that are cost-effective over the whole of life of the transportation network;
- h) A transportation network that is resilient;
- i) A transportation system that encourages and enables a shift to renewable energy sources;
- j) A transport system that does not contribute to flood hazard and manages the effects of water contamination and habitat loss from stormwater discharges;
- k) A transport system that enables positive well-being outcomes by providing active transport choices, reducing transport emissions, and providing space for people to meet and interact.

4.1.2 Creating Good Infrastructure – Design-Led Approach

The aim of this chapter is to enable good urban structure to be developed. It encourages a design-led approach rather than specification of minimum standards. This is to encourage quality thinking, collaboration and innovation to reach optimum solutions that align with the performance outcomes listed in Section 4.1 above.

A design-led approach to transportation begins with the foundation of well-designed urban structure, by acquiring a good understanding of the urban design principles which underlie the layout of blocks, streets and open spaces in new developments and the inter-relationship between them.

While the focus is on new public spaces, designers are also encouraged to consider the three-dimensional character of the spaces that are formed by buildings on private areas within the blocks. The relationship between public and private areas is an essential part of creating places for people.

Access to, and within, areas to be developed includes more than the road network that provides formal access to properties. It includes public transport routes and green linkages, such as reserves and greenways that provide access for pedestrians and cyclists

The road network and associated linkages need to be highly connected, to reflect the desire lines and destinations within the area and also in surrounding neighbourhoods. This encourages people to walk or cycle where practicable, rather than using their car, particularly for shorter local trips. When this can be achieved, it results in energy savings and creates a safer and more pleasant neighbourhood.

4.2 Referenced Documents

4.2.1 Resource Management Plan Requirements

The standards set out in this chapter address matters that are specific to Council asset creation or activities that may have an impact on an asset. These activities are also subject to the respective Nelson City and Tasman District RMPs. Key sections of the Plans that relate to transportation design and construction in this document are subdivision, land use and transportation infrastructure provisions. This means that both the provisions in the Resource Management Plans and this Land Development Manual do apply.

4.2.2 Document and Standards

This document governs a design led approach to transportation. However, additional advice and guidance can be found in Table 4-1. Where an Act or National Standards document is referenced, this must be the current version including any associated amendments.

Table 4-1 Documents, Standards and References

Standard	Comment
AS/NZS 1170	Structural Design Actions
AS/NZS 2890	Parking facilities – Part 1: Off-street car parking and Part 6: Off-street for people with disabilities
AS/NZS 4819	Rural and Urban addressing
AS/NZS 1158	Lighting for roads and public spaces
NZS 3104	Specification for concrete production
NZS 4402	Methods of testing soils for civil engineering purposes
NZS 4404	Land development and subdivision infrastructure
NZS 4431	Code of practice for earth fill for residential development
NZS 3116	Concrete segmental and flagstone paving
Austroads	Austroads Guide to Road Design: Parts 1-8
	Austroads Guide to Pavement Technology Part 2: Pavement Structural Design
	Austroads Guide to Road Safety - Part 6 Road Safety Audit at: http://www.austroads.com.au/road-operations/road-safety/resources/guide-to-road-safety
New Zealand Transport Agency	Pedestrian Planning and Design Guide
	Cycle network guidance – planning and design https://www.nzta.govt.nz/walking-cycling-and-public-transport/cycling/cycling-network-guidance
	Manual of Traffic Signs and Markings (MOTSAM) Part I – Traffic Signs & Part II – Markings
	Traffic control devices manual
	Road and Traffic Guideline RTS 14 ‘Guidelines for facilities for blind and vision-impaired pedestrians’

Standard	Comment
	Road Safety Audit Report Template https://www.nzta.govt.nz/resources/road-safety-audit-procedures/ Economic Evaluation Manual M23 Road Safety Barrier Systems NZTA F/1 Earthworks Construction NZTA F/2 Pipe Subsoil Drain Construction NZTA F/3 Pipe Culvert Construction NZTA M/1 Roothing Bitumens NZTA M/4 Basecourse Aggregates NZTA M/6 Sealing Chip NZTA M/10 Asphaltic Concrete NZTA M/13 Adhesion Agents NZTA P/3 First Coat Sealing NZTA P/9 Construction of Asphalt Concrete Paving NZTA P33: 2017 Coloured Surfacing NZTA Bridge Manual
Ministry of Justice	National Guidelines for Crime Prevention through Environmental Design in New Zealand.
Tasman District Council Policies and Procedures	Procedure for Naming Rights of Way and Private Roads https://www.tasman.govt.nz/my-council/key-documents/more/growth/development-and-financial-contributions-policy/#e1330 Road Naming https://www.tasman.govt.nz/my-council/key-documents/more/growth/development-and-financial-contributions-policy/#e1330 Road Delineation Policy http://www.tasman.govt.nz/policy/policies/roading-policies/road-delineation/
Nelson City Council – Out and About Policy	The Out and About Active Travel and Pathway-based Recreation Policy covers physical activities on Nelson roads, footpaths and pathways, either for travel or recreation purposes. http://nelson.govt.nz/council/plans-strategies-policies/strategies-plans-policies-reports-and-studies-a-z/out-and-about-policy
Tasman District Council – Connecting Tasman	Connecting Tasman is an overarching regional transport strategy. http://www.tasman.govt.nz/policy/policies/roading-policies/

4.2.3 Transport Network

A Transportation Network Concept Plan is to be submitted to Council based on the design-led philosophy and requirements of sections 4.3, 4.4 and 4.5.

STANDARDS

4.3 Design Process

This section sets out the process of designing a transportation network that can meet the Performance Outcomes listed in section 4.1.

Mandatory Matters

4.3.1 General

The network design must be led by or include:

4.3.1.1 Performance outcomes of 4.1.

4.3.1.2 Except as provided for by f) the recommendations of a Transportation Assessment Report (TAR) by a suitably qualified and experienced transportation engineer that shows that the proposed design can meet the transport performance outcomes set out in Section 4.1. The TAR focus is on the following information:

- a) Intended speed environment of the road network.
- b) Anticipated road capacity.
- c) Points of connection within the location and with adjoining vehicle and non-vehicle accessways.
- d) Opportunities for multifunctional use of transportation corridors, such as stormwater management, reserves, amenity features and neighbourhood parking.
- e) Integration with existing and proposed bus and active transport networks; and Road function in terms of proposed development and local road hierarchy.
- f) The TAR requirement in section 4.3.1.2 may be replaced with:

“Approval at the Engineering Manager’s discretion following written advice prepared by the developer’s design team that demonstrates the proposal is not sufficiently complex to justify a TAR”.

4.3.1.3 Information that is gathered by the design team, and made available to Council as part of the transport network design process, to address the following features where applicable:

- a) Existing natural features and topography, including freshwater resources, drainage features, and soil and substrate conditions;
- b) Relevant RMP map overlay features, such as zones, area overlays, indicative roads and greenways;
- c) Existing built features within the location and within the surrounding environment, including buildings, and the location of existing stormwater reticulation, water and wastewater services;
- d) Any structure plans;

- e) Proposed stormwater management for the location, including any concept plans, resource consent approvals; and
- f) Hazards, including seismic risk locations, geotechnical instability, flood hazard, erosion and sea level rise inundation risk locations.

4.3.1.4 A road safety audit report by a team of at least two suitably qualified and experienced road safety engineers. The safety audit stage will depend on the complexity of the proposed or existing transport network, the form of its intersections and the level of active transport activity and the size of the development as shown in Table 4-2 below.

Table 4-2 Road Safety Audit Stage Requirements

Development Type	Road Safety Audit Stage			
	Concept	Scheme or preliminary design (with or prior to Resource consent application)	Detailed Design	Pre-Opening or Post Construction
Access onto, or modification to or construction of State Highway, Arterial or Principal roads	Recommended	Required	Required	Required
Access onto, modification to or construction of Collector and Sub Collector roads	Recommended	Required	Required	Recommended
Access onto, modification to or construction of Local Roads, Residential Lanes, and Service lanes	Recommended	Required	Recommended	Recommended
Access via, modification to or construction of a signalised intersection or roundabout on any hierarchy road	Recommended	Required	Required	Required
Significant active transport infrastructure (walk cycle)	Recommended	Required	Required	Required
Development involving the creation of more than 20 household units or 20 carpark spaces for non-residential activities	Recommended	Required	Required	Recommended

4.3.1.5 Exemption from providing road safety audits may be granted by the Engineering Manager at its sole discretion.

4.3.1.6 Road safety audits are to be provided for private road networks when considered necessary by the Engineering Manager.

- 4.3.1.7 Any recommendations of the Safety Audits are to be implemented by the owner/developer to the Engineering Manager's satisfaction.
- 4.3.1.8 Note: if a development involves multiple development types as listed in Table 4-2, the road safety audits will be holistic documents that covers the entire development with the highest requirement governing the number of stages required.
- 4.3.1.9 The audit procedure and report will be undertaken using the guidance set out in Austroads Guide to Road Safety - Part 6 Road Safety Audit at: <http://www.austroads.com.au/road-operations/road-safety/resources/guide-to-road-safety> and using the template provided at <https://www.nzta.govt.nz/resources/road-safety-audit-procedures>.

Good Practice

The following matters provide additional direction and guidance in the process of determining an appropriate transportation network.

4.3.2 General

- 4.3.2.1 The Designer may meet with Council Engineering and Planning staff to discuss opportunities and constraints for a transportation network based on the above information requirements of section 4.3.1.
- 4.3.2.2 Council may require additional information in support of any proposed design, and further assessment to show that performance outcomes can be met.

4.4 Network Layout Form and Function Design

This section sets out design standards for the layout, form and function of the transportation network.

Mandatory Matters

Council requires the following standards to be met in the design of the layout, form and function of the Road network:

4.4.1 Road Hierarchy

- 4.4.1.1 Each road within the proposed design must be defined in terms of its form and function according to the road hierarchy, as set out in this section.
- 4.4.1.2 All roads with a hierarchical classification of State Highway, Arterial, Principal and Collector are grouped and termed 'Classified Roads'.
- 4.4.1.3 Sub-Collector Roads, Local Roads, Residential Lanes, and Private Ways serving more than four actual or potential lots are 'Unclassified Roads'.
- 4.4.1.4 Shopping Streets will not be categorised Classified or Unclassified and will be subject to specific design.

Table 4-3 Road Hierarchy

Hierarchy	Description	ONRC ¹
State Highways	<p>State Highways are primary roads in the strategic road network linking Nelson and Tasman to other areas of the country.</p> <p>Safe and efficient mobility along the corridor will be the principal function of State Highways, with access to adjacent land being a subordinate function. State Highways will be constructed and managed by the New Zealand Transport Agency.</p>	Regional, Arterial, Primary Collector or Secondary Collector
Arterial Roads	<p>Arterial roads will be designed to join centres of population within regions and neighbouring regions and provide links to the higher order State Highway network. Safe and efficient mobility along the corridor is the principal function of Arterials with access to adjacent land being a subordinate function. Arterial roads are constructed and managed to minimise their local access function.</p>	Regional or Arterial
Principal Roads	<p>Principal roads will connect and augment the higher order transport system. These roads link adjacent suburbs, smaller centres and areas of population and facilitate movement to and access of major attractors and industrial areas.</p> <p>Principal roads will have multiple functions of moving people and goods safely and efficiently whilst also providing access to major employment areas and attractors and movement across corridors. The function of mobility along Principal roads will not dominate the management of the corridor to the detriment of access to adjacent land use.</p> <p>The effects of traffic generated by adjacent land use will not detract from the mobility function of the corridor of a Principal road.</p> <p>Principal Roads will accommodate short to medium length trips associated with through traffic and local traffic.</p> <p>Public transport, walking and cycling will be accommodated within Principal Roads.</p>	Primary Collector
Shopping Streets (Tasman) and City Streets (Nelson)	<p>Shopping Streets have a range of functions, which means a 'design led' approach is required for them.</p> <p>Therefore, they are not categorised, i.e. neither Classified nor Unclassified. Typically, these roads provide high levels of pedestrian priority, on-road parking supply, amenity, and local traffic circulation/servicing.</p>	NA

¹ One Road Network Classification (ONRC) is shown in

Table 4-3 for information only. The ONRC classification of Council's roads is its current function classification used primarily for funding and activity management purposes only.

Hierarchy	Description	ONRC ¹
Collector Roads	<p>Collector roads will be designed to distribute traffic between and within local areas and form a link between higher order (Principal and Arterial) roads and lower order (Sub-Collector and Local) roads.</p> <p>Collector Roads will be designed to accommodate local traffic and provide access to adjoining property. In the urban area, Collector roads must have a predominantly residential frontage and where required, contain the bus routes within the neighbourhood.</p>	Primary or Secondary Collector
Sub Collector Roads	<p>Sub-Collector roads will be designed to distribute the vehicular traffic at a neighbourhood level and form the link between Collector roads and Local roads. A high proportion of traffic on these roads has an origin or destination within the immediate area.</p> <p>In residential areas, Sub-Collector roads must provide high levels of amenity and prioritise access to adjoining property over local traffic movements. Through traffic is not a desired outcome for Sub-Collector roads.</p>	Secondary Collector or Access
Local Roads	<p>Local roads will be designed for the primary function of providing direct access to properties fronting the access road and along which only traffic having an origin or destination will travel. Pedestrian and local amenity values predominant.</p> <p>Local roads must also be designed to ensure a safe and high amenity environment for pedestrians and cyclists, so that the road is a shared multi-functional public space</p>	Access or Low Volume
Residential Lanes	<p>Residential Lanes are public roads that will be designed to provide access for between seven and 20 residential units.</p> <p>Residential lanes will be designed to have the visual appearance of a Private Access Way, to discourage use by non-local vehicular traffic. Vehicular and pedestrian access to frontage properties is the key function.</p>	Low Volume
Service Lanes	<p>Service Lanes will be designed for the purpose of providing side or rear access for vehicular traffic to land in industrial or commercial areas. When their construction has been completed, they may be made into private rights of way.</p> <p>No parking or separate pedestrian facilities are required to be provided on Services Lanes</p>	Low Volume
Private Access	<p>Private access includes rights of way, access lots and private driveways and are for providing access over private land to private property.</p> <p>Access to private residential areas can only serve up to six potential residential units. If there is potential for more than six residential units then a private access is inappropriate, and access should be designed to be taken from a public road.</p>	NA
Public Accessway	<p>An Accessway is a path providing pedestrian and cycle access between two or more public roads or between a road and a reserve. This is schematically illustrated in Figure 4-2. An accessway may service a number of properties along its length.</p>	NA

4.4.2 Design within the Hierarchy

When determining road form and function within the hierarchy, the following matters must be addressed in the design and discussed in the TAR:

- 4.4.2.1 Connectivity, to ensure the efficient and logical movement of people from place to place;
- 4.4.2.2 Amenity of the street and/or neighbourhood;
- 4.4.2.3 Design that encourages appropriate traffic speeds and operating conditions across the various elements of the transport network;
- 4.4.2.4 A layout that enables easy organisation and management of the transport network;
- 4.4.2.5 A layout that prioritised safety of the transport network; and
- 4.4.2.6 Choice of road that seeks opportunities to address land use and/or transport deficiencies from a number of land use or transport investment perspectives.
- 4.4.2.7 The inter-relationship of the road hierarchy is illustrated schematically in Figure 4-2.

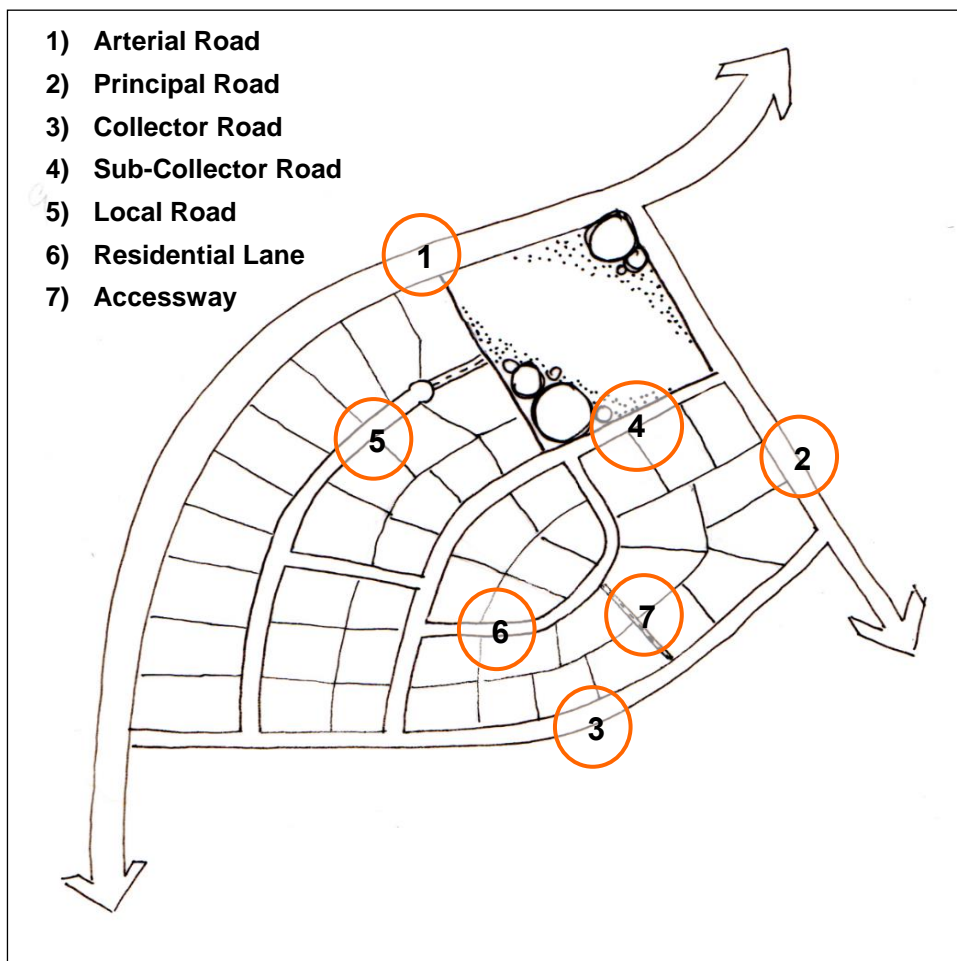

Figure 4-2 Inter-relationship of Road Hierarchy

4.4.3 Minimum Intersection Spacing

Minimum intersection spacing will be:

- 4.4.3.1 The minimum centreline to centreline separation of any two roads with regulatory speeds of 50km/h or below intersecting an urban 'Classified Road' will be 110m, increased to 150m where the intersecting roads meet the 'Classified Road' in a left-right stagger;
- 4.4.3.2 Intersections of urban 'Unclassified Roads' with regulatory speeds of 50km/h or below will provide a minimum centreline to centreline separation of 40m; and
- 4.4.3.3 The intersection spacing rules for speeds of 50km/h or below is schematically illustrated in Figure 4-3.
- 4.4.3.4 For roads with regulatory speeds above 50km/h the minimum intersection will be as show in Table 4-4.

Table 4-4 Intersection Spacing above 50Km/h

Regulatory Speed (km/h)	Minimum Intersection Spacing (m)
100	800
80	550
70	220
60	160

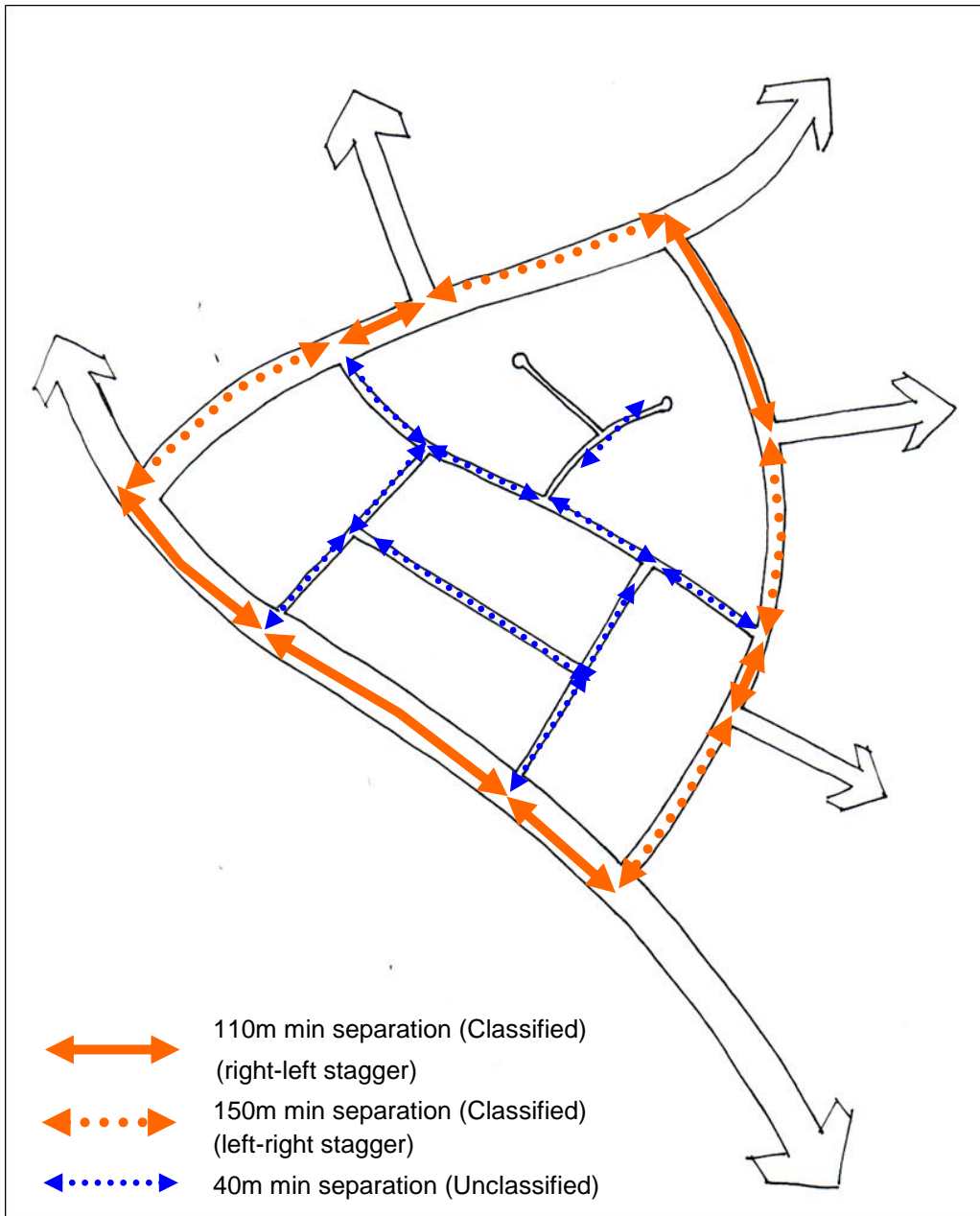

Figure 4-3 Minimum Intersection Separation in areas with a regulatory speed of 50km/h or below

4.4.4 Connectivity

- 4.4.4.1 Where future development on adjoining land is possible, land within the development will be set aside to ensure that future connection is not precluded. The spacing of road connections to adjacent future areas should consider the potential future network requirements of the wider area.
- 4.4.4.2 Cul-de-sacs that may function as future through roads must be designed to the standard of the future function.
- 4.4.4.3 Isolation strips will not be permitted when properties are developed.

4.4.4.4 The number and length of cul-de-sacs will be minimised, to encourage connectivity and navigability. The roading layout presented in Figure 4-4 shows a layout where the entire road network off the main road would be classified as a long cul-de-sac and is not permitted. The roading layout presented in Figure 4-5 shows how a connected road network can reduce the prevalence of cul-de-sacs.

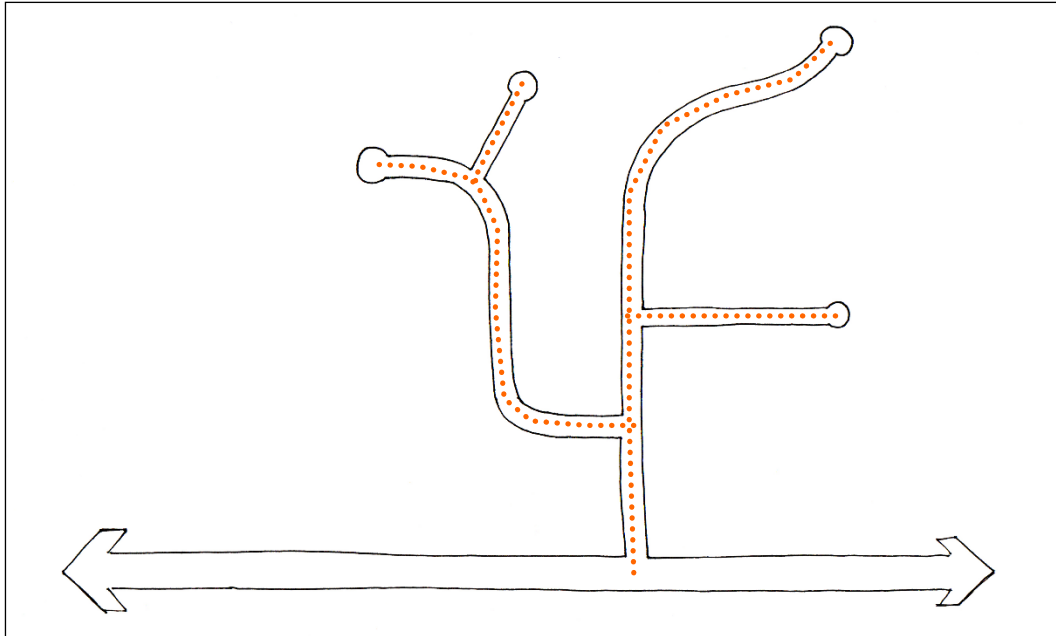

Figure 4-4 Extent of Cul-de-sac – Not Permitted

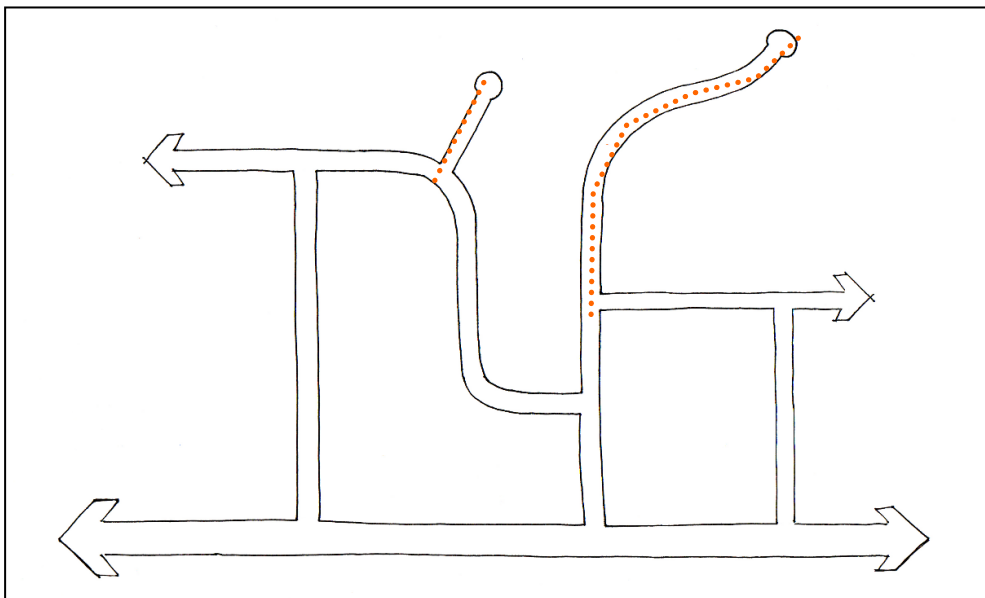

Figure 4-5 Extent of Cul-de-sacs - Permitted

4.4.4.5 A cul-de-sac in residential zones will be no longer than 150m and serve no more than 25 potential residential dwellings, except in 'Hillside Environments' where subject to the Engineering Manager's approval a cul-de-sac may have a length of up to 400m while serving no more than 40 potential residential dwellings.

- 4.4.4.6 No more than 15 per cent of lots in any residential zone development, except in ‘Hillside Environments’, will have frontage to a cul-de-sac.
- 4.4.4.7 A cul-de-sac in Commercial or Industrial zones will be no longer than 120m.
- 4.4.4.8 Cul-de-sacs must be designed so that pedestrians and cyclists have through access, especially where that access would link to local facilities, other roads or recreation opportunities, as illustrated in Figure 4-6.

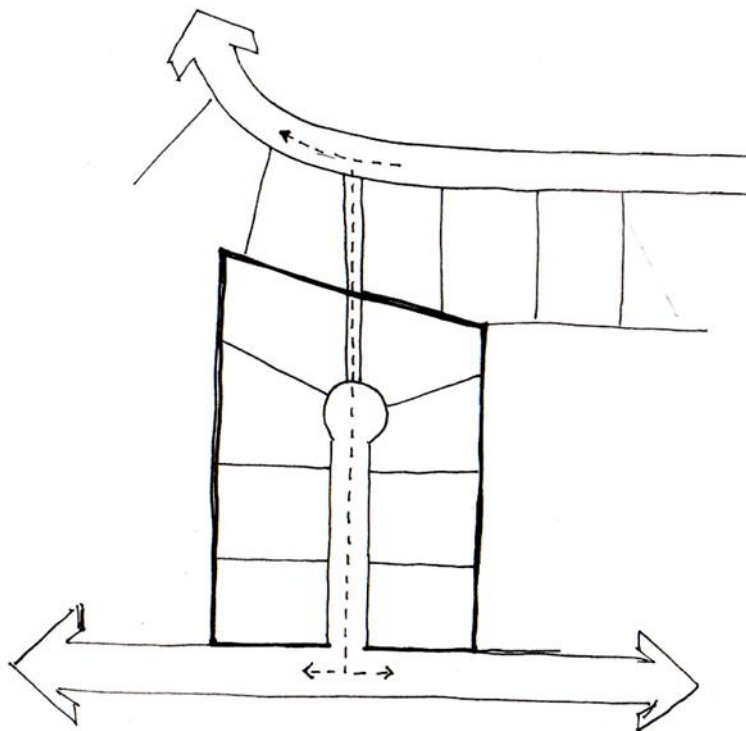

Figure 4-6 Cul-de-sac public accessway connection for active transport

4.4.5 Pedestrian, Cyclist and Public Transportation

- 4.4.5.1 The transport network must facilitate walking, cycling and use of public transport for access to daily activities.

4.4.6 Structures

- 4.4.6.1 The use of retaining walls, bridges and culverts will be subject to Engineering Manager approval.

4.4.7 Commercial Zone Design

- 4.4.7.1 The design of the commercial road layout will include a high amenity berm area for the inclusion of street furniture complementary to the commercial space such as cycle racks, litter bins, amenity planting and seating.

Good Practice

The following matters provide additional direction and guidance in the design of the layout, form and function of the road network:

4.4.8 Layout

- 4.4.8.1 The road layout and form and function design should create a permeable and highly-connected network of roads that enables relatively direct trips in and between neighbourhoods and to local activity points.
- 4.4.8.2 'Unclassified Roads' should be configured to support local traffic moving in and between neighbourhoods and areas.
- 4.4.8.3 To support the function and operation of the road hierarchy, there should be no more than two hierarchy classifications between any intersecting road. For example Local Roads should not intersect Principal Roads or Arterial Roads and Sub-Collector Roads should not intersect Arterial Roads.
- 4.4.8.4 New development should connect well to existing, committed, proposed or potential development in adjacent areas to facilitate interconnection between new and existing communities.
- 4.4.8.5 Road connections to existing areas should ensure that outcomes of the connection, such as increased traffic volumes, will be commensurate with the design of those areas.

4.4.9 Pedestrian, Cyclist and Public Transport Considerations

- 4.4.9.1 The transportation network should not only facilitate private motor vehicle travel, but also encourage walking, cycling, mobility scooter and those with impaired vision and use of public transport for access to daily activities.
- 4.4.9.2 Linkages for pedestrians and cyclists should create an attractive, friendly, connected, safe and accessible environment. These linkages should ensure that people can move about the community freely and safely in areas where there are no road linkages.
- 4.4.9.3 Large blocks (typically of more than 500m) should be avoided in urban areas, as this increases trip lengths which ultimately reduces the attractiveness of making trips by active modes.
- 4.4.9.4 The arrangement of streets, design of buildings, parks and other outdoor spaces should be designed to address crime and the level of fear of crime.
- 4.4.9.5 The layout should enhance personal safety and perceptions of safety, and minimise potential for crime, vandalism and fear by ensuring that roads and open spaces are overlooked by housing and actively used facilities to enable people to feel more comfortable outdoors.
- 4.4.9.6 To ensure that crime prevention is properly taken into account, it is important that the way in which permeability is provided is given careful consideration. A highly permeable and connected transport network is conducive to walking and cycling, but can lead to problems

of anti-social behaviour if it is only achieved by providing routes that are poorly overlooked or lack inter-visibility such as enclosed public accessways for walking and cycling.

4.4.9.7 Guidance for achieving development that provides high levels of surveillance to the transport network is provided in the Crime Prevention through Environmental Design (CPTED) Guidelines (2005). The Engineering Manager may consider variations from these principles where it is satisfied that variations are justified in terms of the following criteria:

- a) The design is constrained by topography, geology or existing development and ideal solutions are neither practical nor viable;
- b) Where compromises are desirable to maintain integrity of the network, to establish effective connections or maintain continuity along a route.

4.4.9.8 Pedestrian access should connect a high proportion of households as directly as practical to a range of facilities, including but not limited to reserves, bus stops, local shops, schools, place of employment, and medical facilities. i.e. Desire lines should be as short as practical.

4.4.10 Intersections

4.4.10.1 On 'Classified Roads' a balance should be found between achieving a permeable and connected walking network and greater importance is placed on these roads for the through movement function in urban areas.

4.4.10.2 Close intersection spacing should be avoided on busy roads to prevent:

- a) Confusing and unsafe driving environments;
- b) Reduced movement function of the corridor; and
- c) Deterring active users, as each intersection increases the pedestrian's and cyclist's exposure to a greater number of potential conflict situations from vehicles turning into and out of side roads.

4.4.10.3 Intersections on Principal and Arterial roads that are controlled by traffic signals or roundabouts should have greater separation (as assessed on a case-by-case basis) to balance movement for through traffic with the needs of local traffic and access.

4.4.10.4 Access designs for rural activities including dwellings and commercial and industrial are shown on SD409.

4.4.11 Design for Larger Vehicles

4.4.11.1 The most common type of service vehicle accessing residential areas will be those associated with regular waste collection. The operation of waste collection services should be an integral part of road design and achieved in ways that do not detract from road environment amenity.

4.4.11.2 While it is always possible to design new roads to take the largest vehicle that could be manufactured, this would conflict with the desire to create quality places and create low speed environments in local residential areas.

4.4.11.3 The design of roads will accommodate service vehicles without allowing their requirements to dominate the layout. Refer section 4.9.3.2 for large vehicle design mandatory requirements at intersections.

4.4.11.4 Larger vehicles which are only expected to use a road infrequently, such as furniture removal vehicles, need not be fully accommodated on 'Unclassified Roads'.

4.4.12 Use of Residential Lanes

4.4.12.1 Council will consider allowing a Residential Lane where:

- a) The natural or physical constraints inhibits or precludes construction of an access road to a Local Road standard; or
- b) The lane would only serve dwellings on one side, the other side borders a riparian strip or other land accessed from elsewhere; or
- c) Vehicular access is required to the rear of residential properties that have frontage, but no vehicular access to a 'Classified Road'; or
- d) A Residential Lane is the most efficient form of access for a residential intensification / infill development.

4.5 Design for the Speed Environment

This section outlines standards and guidance for the design of roads that create a safe speed environment, consistent with road form and function.

Mandatory Matters

Council requires the following standards to be met in the design of roads:

4.5.1 Design for Target Speed

4.5.1.1 The road designer will determine the target speed for each road as set out in Table 4-5.

Table 4-5 Target Speed Environment

Road Hierarchy	Classified/Unclassified	Target Speed Environment
Arterial Roads	Classified	Speed Limit
Principal Roads		Speed Limit
Collector Roads		Speed Limit
Sub-Collector Roads	Unclassified	10km/h less than speed limit *
Local Roads		20km/h less than speed limit *
Residential Lanes, Service Lanes		20km/h
Private Ways	NA	20km/h

* Assuming a speed limit of 50km/h. The target speed environment should not be below 30km/h.
 In Rural Lifestyle zones the target speed environment will be a maximum of 60km/h.

- 4.5.1.2 The designer will address each of the following matters in the design of the road, to show how they have been considered in the design of the speed environment to meet the requirements of Table 4-5.
- 4.5.1.3 The width of the road and how it has been designed to encourage speed reduction;
- 4.5.1.4 Road alignment and visibility, and how these elements have been treated to encourage low speeds;
- 4.5.1.5 Road vertical elements, and their effect on the perception of the need to travel cautiously;
- 4.5.1.6 Vegetation, and the effect on visibility to reduce speed without creating traffic safety hazard;
- 4.5.1.7 Parking, and the likely demand for road-side parking as it can affect road speed behaviours;
- 4.5.1.8 Land use activities on adjoining land, especially high traffic generating ones such as schools, community amenities and commercial activities;
- 4.5.1.9 A suitably qualified and experienced traffic engineer will include within the transportation assessment report (TAR) how the proposed design will meet the target speed environment including evidence of the ability of any proposed road design to reduce speeds to the target speed.

4.5.2 Traffic Calming Devices

- 4.5.2.1 The selection of traffic calming devices must be compatible with the intended road function.
- 4.5.2.2 The selection and placement of traffic calming devices will be consistent with Austroads Guide to Traffic Management: Part 8 – Local Area Traffic Management. Any device will require Council's approval.
- 4.5.2.3 Speed humps and other vertical speed control devices cannot be used on Sub Collector, Collectors, Principal or Arterial roads nor state Highways.

Good Practice

The following matters provide additional direction and guidance in designing for the speed environment.

4.5.3 Speed Environment

- 4.5.3.1 The speed environment of roads within a transport network should reflect the function of each road in the context of the environment through which it travels.
- 4.5.3.2 Unclassified roads in residential areas should be designed to create low speed environments where pedestrians and cyclists can safely and comfortably share road space with motorised traffic.

4.5.4 Speed Reduction Measures

4.5.4.1 The following techniques can be used to achieve a lower speed environment, to make the road more conducive to accommodating all road users and improving neighbourhood amenity, including:

- a) Forward visibility – reducing lines of sight has the greatest effect on the speed environment at both intersections and at mid-block locations;
- b) Carriageway width – a narrow carriageway will generally result in a lower speed environment, especially when combined with reduced forward visibility and the presence of parked vehicles;
- c) Parking – parked vehicles generally create a speed environment that is 3 to 8km/h lower than when parking does not occur;
- d) Landscaping – appropriately designed on-road landscaping can visually narrow the road. It can also be used with changes to the kerb alignment to physically narrow the carriageway;
- e) Geometry – long, straight roads are beneficial in optimising connections between places to better serve the needs of pedestrians who prefer direct routes. However, roads with this geometry also create higher speed environments. Consideration should be given to providing short and curved or irregular roads whilst avoiding excessive or gratuitous curves that are less efficient and make access for pedestrians and cyclists more difficult;
- f) Intersection spacing – On Local roads short lengths of road between intersections make it difficult to reach higher speeds;
- g) Intersection design – small kerb radii force motorists to slow down when entering an intersection. This can be combined with an intersection treatment (for example; change in road width or surfacing) to indicate a change in the speed environment to drivers;
- h) Traffic calming – localised road narrowing, changes in road texture, changes in the road alignment (both horizontal and vertical) can all be used to reduce speeds;
- i) Thresholds – localised narrowing of the road through kerbs, road markings, signage and/or roadside planting can provide a signal to drivers that they are entering an area with a lower desired speed environment.

4.5.4.2 The above speed reduction measures do not represent a library to pick from but rather a summary of potential options for contributing to speed reduction.

4.5.4.3 Overuse of traffic calming measures will reduce their effectiveness globally, as will the passage of time reduce it locally, as drivers become familiar with them. Regardless of this, ensure a degree of consistency in the use of traffic calming measures as provided below:

- a) Use similar devices in similar ways;
- b) Design measures so that drivers can recognise and react to them appropriately both in approach speed and alignment.

4.6 Transport Cross-Sections

This section outlines Council's expectations for road widths and features to be included in the cross-section design of transport corridors.

Mandatory Matters

Council requires the following standards to be met in the design of transport cross-sections:

4.6.1 General

- 4.6.1.1 The number and minimum widths (specified in metres) of key road elements, categorised by hierarchy, are shown in Table 4-6 for Collector, Principal and Arterial Roads (Classified) and in Table 4-7 for Sub-Collector Roads, Local Roads, Residential Lanes and Service Lanes (Unclassified), see also SD411.
- 4.6.1.2 Where an existing road is developed along its frontage and that road does not have the required road reserve width, road to vest will be required along that frontage and be vested with Council without compensation.
- 4.6.1.3 As a condition of consent, the road frontage must be upgraded to the required design for that category of road at the cost of the developer.
- 4.6.1.4 Stormwater quality treatment design is required on most classified roads, refer section 5.3.8 for details.

Table 4-6 Minimum Provision and Width of Elements for 'Classified Roads'

Hierarchy	Zoning ¹	Traffic Lanes	Flush Median	Cycle Facility	Parking	Berm (Shoulder for rural)	Footpath ²	Service Strip ³	Legal Road Reserve Width ⁴
State Highway	Controlled by NZTA - Subject to specific design								
Arterial Roads	Residential (all)	2 x 3.5	1 x 2.0	Uni-directional separated paths	⁶	2 x 1.5	2 x 2.0	2 x 1.6	25
	Commercial (all)	2 x 3.5	1 x 2.0	2 x 2.3 paths with 2 x 1.0m min separating strips ⁵ to driving lane and/or 0.6m separation to parking and/or 0.2m to footpath	2 x 2.3	2 x 2.0	2 x 3.0	-	30
	Industrial (all)	2 x 3.5	1 x 2.0		⁶	2 x 1.5	2 x 2.0	2 x 1.6	25
	Rural Lifestyle (all)	2 x 3.5	-	Shared path 2 x 2.5	-	Sealed 2 x 1.5	-	-	22
	Rural (all)	2 x 3.5	-	Sealed cycle lane 2 x 2.5 ⁷	-	Sealed 2 x 1.5	-	-	20
Principal Roads	Residential (all)	2 x 3.0	1 x 2.0	Uni-directional separated paths	2 x 2.0	2 x 1.5	2 x 1.5	2 x 1.6	27
	Commercial (all)	2 x 3.0	1 x 2.0	2 x 2.3m path with 2 x 1.0m min separating strips ⁵ to parking and/or 0.2m to footpath	2 x 2.3	2 x 2.0	2 x 3.0	-	29
	Industrial (all)	2 x 3.5	1 x 2.0		2 x 2.3	2 x 1.5	2 x 1.5	2 x 1.6	28
	Rural Lifestyle (all)	2 x 3.25	-	Shared path 2 x 2.5	-	Sealed 2 x 1.5	-	-	21
	Rural (all)	2 x 3.25	-	Sealed cycle lane 2 x 2.5 ^{7&9}	-	Sealed 2 x 1.5	-	-	20
Shopping Streets	Subject to specific design								
Collector Roads	Residential (all)	2 x 3.0	-	Uni-directional separated paths	2 x 2.0	2 x 2.0	2 x 1.5	2 x 1.6	24
	Commercial (all)	2 x 3.0	-	2 x 2.0m path with 2 x 0.6m min separating strips to parking and/or 0.2m to footpath	2 x 2.3	2 x 2.0	2 x 3.0	-	26
	Industrial ⁸ (all)	2 x 3.5	-		2 x 2.3	2 x 1.5	2 x 1.5	2 x 1.6	26
	Rural Lifestyle (all)	2 x 3.0	-	1 x 2.5m Shared Path	-	2 x 600mm Metal	-	-	20
	Rural (all)	2 x 3.0	-	2 x 2.5m Sealed Cycle Lanes ^{7&9}	-	2 x 600mm Metal	-	-	20

¹ Where a road or access serves land in more than one zone the requirements for footpaths and berms on each side of the road or access will be the maximum required for any of the adjoining zones.

² Where a road fronts a reserve that has a footpath aligned parallel to, and in close proximity of the road reserve boundary, then a footpath is not required to be provided within the road reserve on that side of the road. Where a road is situated close to a school, aged care facility, church, sports field or other high pedestrian generating community facility, the footpaths to be widened to 2.0m minimum.

³ The 'Service Strip' may be reduced to 0.5m where there is sufficient space to locate services under the footpath without precluding the introduction of street trees.

⁴ The final legal road reserve width may vary from the legal road reserve width shown in Table 4-6. The indicative legal road widths assume that all elements are provided to the minimum width and located alongside one another with no cut or fill batters.

⁵ A narrower Road Reserve width will be acceptable to Council if the 'Berm' and cycle facility separating strip are able to be combined into a single 1.5m landscaped strip except in the Commercial zone.

⁶ If there is existing parking demand then provide 2.0m width in residential zones and 2.3m width in industrial zones.

⁷ Cycle separating strips and the berm area should be combined, subject to specific design that considers operating speed, appropriate separation, heavy vehicle, vehicle and cycle volumes.

⁸ Zoning refers to the generic zone reference in zone terminology of Chapter 3 – Definitions.

⁹ The cycle facility in rural zones may be omitted if there is no current or future demand at the sole discretion of the Engineering Manager.

Table 4-7 Minimum Provision and Width of Elements for ‘Unclassified Roads’

Hierarchy	Zoning ¹	Traffic Lanes	Cycle Facility	Parking	Berm ² (Shoulder for Rural)	Footpath ^{2&3}	Service Strip ⁴	Legal Road Reserve Width
Sub -Collector Roads	Residential (all)	1 x 5.6	- ⁸	1 carpark/2 dwellings ⁷ Or 2 x 2.0	Min 0.3m, Max 6.0m Area ≥ 3.0m ² /lm averaged over 50m Or 2 x 1.5	2 x 1.5	2 x 1.6	19
	Commercial (all)	1 x 5.6	- ⁸	2 x 2.3	2 x 2.0	2 x 3.0	-	21
	Industrial (all)	2 x 3.25	- ⁸	2 x 2.3	2 x 1.5	1 x 1.5	2 x 1.6	19
	Rural Lifestyle (all)	1 x 6.0	1 x 2.5m Shared Path	-	2 x 600 Metal	-	-	16
	Rural (all)	1 x 6.0	1 x 2.5m Shared Path ⁹	-	2 x 600 Metal	-	-	16
Local Roads	Residential (all)	1 x 5.5	- ⁸	1 carpark/2 dwellings ⁷ Or 2 x 2.0	Min 0.3m, Max 6.0m Area ≥ 3.0m ² /lm averaged over 50m Or 2 x 1.5	2 x 1.5	2 x 1.6	19
	Residential (< 20 dwellings) (all)	1 x 5.5 ^{5&6}	- ⁸	1 carpark/2 dwellings ⁷ Or 2 x 2.0	Min 0.3m, Max 6.0m Area ≥ 3.0m ² /lm averaged over 50m Or 2 x 1.5	1 x 1.5	2 x 1.6	13
	Commercial (all)	1 x 5.6	- ⁸	2 x 2.3	2 x 2.0	2 x 3.0	-	21
	Industrial (all)	2 x 3.25	- ⁸	2 x 2.3	2 x 1.5	1 x 1.5	2 x 1.6	19
	Rural Lifestyle (all)	1 x 6.0	1 x 2.5m Shared Path	-	2 x 600mm Metal	-	-	14
Rural (all)	1 x 6.0	1 x 2.5m Shared Path ⁹	-	2 x 600mm Metal	-	-	14	
Residential Lane ¹⁰	Residential (7 to 20 dwellings)	1 x 5.5 ^{6&7}	-	2.2 Indented bays ⁷	Min 0.3m, Max 6.0m Area ≥ 1.5m ² /lm averaged over 50m Or 1 x 1.5	1 x 1.5	1 x 0.5	9 ¹¹

¹ Where a road or access serves land in more than one zone the requirements for footpaths and berms on each side of the road or access will be the maximum required for any of the adjoining zones.

² In ‘Hillside Environments’ on unclassified roads in Nelson the berm and footpath may be excluded from the uphill side of the road. In Tasman “Hillside Environments” all roads, berms and footpaths require careful specific design to the satisfaction of the Engineering Manager.

³ Where a road fronts a reserve that has a footpath aligned parallel to, and in close proximity of the road reserve boundary, then a footpath is not required to be provided within the road reserve on that side of the road. Where a road is situated close to a school, aged care facility, church, sports field or other high pedestrian generating community facility, the footpaths to be widened to 2.0m minimum.

⁴ The ‘Service Strip’ may be reduced to 0.5m where there is sufficient space to locate services under the footpath without precluding the introduction of street trees.

⁵ Passing bays will be provided at least every 50m or where appropriate. Mutual driveways may be used as passing bays. The minimum dimensions for a passing bay are a width of 5.5m (including carriageway) and minimum length of 6.0m with a 4.0m long taper at each end).

⁶ The requirement is 5.5m for the first 12m from any intersection with higher order roads (Local Roads and above). Thereafter, the traffic lane width may be narrowed to 3.5m. Mutual driveways will be provided at adjoining lot boundaries (12.0m total width) to function as passing bays at least every 50m. The minimum dimensions for a passing bay are a width of 5.5m (including carriageway) and minimum length of 6.0m with a 4.0m long taper at each end).

⁷ Refer clause 4.12.1.1

⁸ Cycle facilities not required provided design allows shared space with low speed environment.

⁹ The cycle facility in rural zones may be omitted if there is no current or future demand.at the sole discretion of the Engineering Manager

¹⁰ A road will only be designed and constructed as a Residential Lane with the prior approval of the Engineering Manager when considering the factors in section 4.4.12.

¹¹ The final legal road reserve width may vary from the legal road reserve width shown in Table 4-6. The indicative legal road widths assume that all elements are provided to the minimum width and located alongside one another with no cut or fill batters.

4.6.2 Shoulder Design

- 4.6.2.1 The shoulder will be widened to 2.5m on the outside of any curve less than 1000m radius on rural classified roads in accordance with Austroads Part 3 Guide to Rural Road Design section 4.3.4, to allow erring drivers to be able to recover safely back onto the road.

4.6.3 Flush Medians

- 4.6.3.1 Flush medians will be widened at intersections and at the access to high traffic generating activities to accommodate turning bays.
- 4.6.3.2 Flush medians that accommodate a pedestrian and or cycle island must be at least 2.4m wide. For marking details refer to the NZTA Manual of Traffic Signs and Markings (MOTSAM) Part II – Markings.

4.6.4 Turning Area Design

- 4.6.4.1 A turning facility will be provided at the end of all cul-de-sacs.
- 4.6.4.2 The minimum radius of the turning circle of a cul-de-sac will be 7m in residential zones, 11m in commercial, 12m in industrial areas and 8.0m in rural lifestyle areas, as per SD417 'Cul-de-sac Turning Circles'.
- 4.6.4.3 Residential Lanes that have only one intersection with higher order roads must be designed with a turning area at the head.
- 4.6.4.4 The berm or shoulder just prior to the turning area will be designed to incorporate collection areas for waste and recycling collection services as shown in SD417. This is to minimise the health and safety risk of multiple reverse manoeuvres from the refuse vehicle lining up with bins within the turning area. The collection area will be 1.0m² for each property accessed from the turning head.
- 4.6.4.5 For residential cul-de-sacs and Residential Lanes in Nelson 'Hillside Environments' the turning area may be a 'Hammerhead' or 'Fishtail' layout, as indicated in Figure 4-7 provided it is sufficient to allow an 8m medium rigid truck with 10m turning radius to undertake a three-point turn. In Tasman hammerhead or fishtail layouts may be used at the sole discretion of the Engineering Manager.

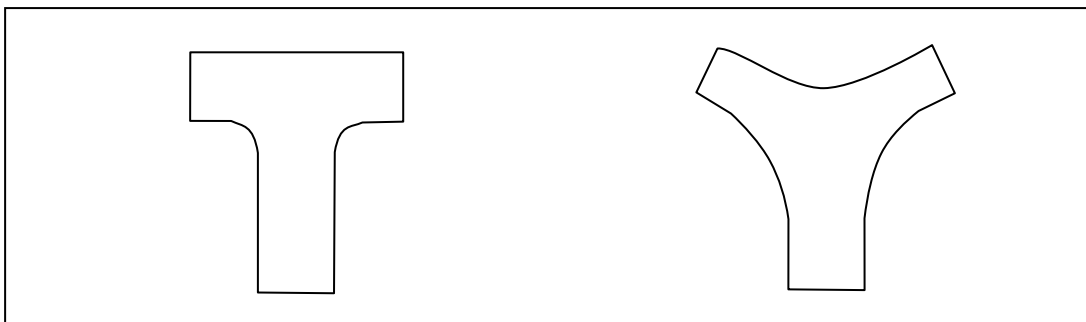

Figure 4-7 Hammerhead and Fishtail Turning Head Arrangements

4.6.5 Staged Road Construction Ends

- 4.6.5.1 Where a road is developed/constructed in stages a turning area will be provided at the end of the construction on the balance land or within at least 20m of the end of the road and be formed, so that all lot frontages can be developed fully, and have access to the legal road. The pavement will be formed to the same standard as the road and permanently surfaced to provide an area sufficient to allow a three-point turn by an 8m medium rigid truck with 10m turning radius.
- 4.6.5.2 Staged road end turning areas must be located within the road reserve area.
- 4.6.5.3 Staged road end turning areas will be removed when the next stage is developed and kerb lines and other associated road elements such as footpaths, streetlights and shoulders extended through at the typical road width to ensure good alignment readability and to minimise the sealed area and its associated ongoing maintenance liability.
- 4.6.5.4 If a lot is created with two road frontages in, then both roads shall be constructed and vested in Council in the one stage. (This allows full development of the corner section and access off the lesser road and connectivity for future landowners). In the unlikely event that a site/lot has vehicle access via one road and also frontage (no vehicle access) to a different road (not a corner site) then road upgrades will be addressed on a case by case basis.

4.6.6 Service Lanes

- 4.6.6.1 Service lanes must:
- Have at least two intersections with higher order roads. Service lanes must not be designed as a cul-de-sac;
 - Have a minimum carriageway width of 4m. Separate parking or pedestrian facilities are not required to be provided.

4.6.7 Services

- 4.6.7.1 The layout of all roads must accommodate infrastructural services and provide convenient access for the maintenance of those services.
- 4.6.7.2 Services are not permitted to be located in the berm between the footpath and the kerb, as this will preclude the planting of street trees. Where street trees are not proposed, the water pipe may be located in this area.
- 4.6.7.3 The width between the kerb and property boundary must be designed to provide sufficient clearance between services. In addition, there must be at least 600mm horizontal separation between the power and the property boundary (refer SD412 and SD413).
- 4.6.7.4 Where street trees are planned, sufficient space must be allowed for them outside of the service corridor with sufficient clearance so that services are not damaged by roots as the trees grow.
- 4.6.7.5 For upgrades to existing roads or the provision of new services in existing roads, services may be located under the service strip adjacent to the property boundary or under the footpath.

Good Practice

The following matters provide additional direction and guidance in the design of transport cross-sections:

4.6.8 General

4.6.8.1 The planning and incorporation of bus routes into a new subdivision should be included as part of the subdivision application. Roads that accommodate or may accommodate a future bus route should be designed in accordance with the requirements specified in Section 4.13.2 Public Transport.

Council may consider variations from Table 4-6 and

4.6.8.2 Table 4-7 where alternative cross-sections and supporting analysis is provided in the TAR.

4.6.9 Legal Road Widths

4.6.9.1 The width of the legal road reserve and carriageway should be sufficient to cater for all functions that the road is expected to fulfil, given the existing zoning of the site and surrounding land, including safe and efficient movement of all users, provision for parking, buffering residents against traffic nuisance, provision of utilities, transport infrastructure, stormwater management, retaining structures and streetscape features.

4.6.9.2 Some of the common factors that will affect the indicative legal road widths are:

- a) On road parking in residential areas may be provided as indented or angled parking bays within the berm area resulting in a variable berm width and ability to introduce a curvilinear alignment to reinforce slow speeds and potentially a narrower overall legal road width;
- b) Where services are located under the footpath in 'Hillside Environments' (refer SD413) the service strip may be reduced to 0.5m;
- c) Cycle facilities, their separation zones and berm areas may be able to be combined. This will result in a narrower overall legal road width;
- d) Some elements may not be required in 'Hillside Environments' to minimise the adverse environmental and amenity effects created by excessive earthworks;
- e) The use of water sensitive design stormwater methods such as swales, which are likely to require additional berm width refer section 5.3.8;
- f) Wider legal road widths may be required to accommodate road retaining structures or earthwork batters.

4.6.9.3 The cross section of new roads or the upgrade of existing ones should take into account the road function, the operating objectives, and the type, density and character of surrounding development.

4.6.9.4 However, on all roads, especially in residential areas, meeting the needs of motorists should not be to the detriment of pedestrians, cyclists and public transport users. Care should be taken to avoid unnecessarily wide roads and verges as this can encourage higher traffic speeds, reduce the amenity of the adjoining land, and discourage pedestrian activity.

4.6.10 Flush Medians

4.6.10.1 Flush medians are intended primarily for urban speed environment conditions with regulatory speeds of 70km/h or less.

4.6.10.2 Flush medians may be appropriate when:

- a) Right turning traffic is interfering with through traffic with the potential for crashes or problems with delays entering the traffic stream;
- b) Pedestrians are having difficulty crossing a busy road;
- c) The carriageway is excessively wide; or
- d) Property access needs to be maintained and any of the above conditions exist.

4.6.11 Turning Areas

4.6.11.1 The road area for manoeuvring should be kept to a minimum to minimise road and land area waste.

4.6.11.2 Opportunities should be taken to incorporate design features such as landscaping, street furniture and central parking spaces to make these areas attractive focal points. Turning areas require a lot of road space and they are generally wasteful in land terms.

4.6.12 Shoulders

4.6.12.1 The shoulder width is measured from the edge of the traffic lane to the berm.

4.6.12.2 All roadside furniture, including landscaping should be located outside the shoulder wherever possible.

4.7 Batter Slope, Bridge and Retaining Structure Design

Batter slopes, retaining walls and bridges are high value components of the transport system with long lives and high ongoing maintenance costs thus getting the design right is critical.

Mandatory Requirements

The following matters are mandatory where slopes or bridge and retaining structures are a factor in the design of the transport system:

4.7.1 Batter Slope

4.7.1.1 All new cut faces must be retained or stabilised with grass.

4.7.1.2 In flat terrain, the bottom edge of the fill batter or the top of a cut batter will start at least 600mm on the roadside of the property boundary. In 'Hillside Environments', the toe of the cut batter may start 1m from the kerb or back of footpath, and the top of the fill batters may start 1m from the kerb or back of footpath (see SD414).

- 4.7.1.3 No batter in either cutting or filling will be steeper than 1.0 vertical to 1.5 horizontal (67%) without the approval of the Engineering Manager, and in certain cases, a geotechnical assessment by a Chartered Professional Engineer (P.Eng.Geol.) will be required to establish the safe batter slope and specific low maintenance landscaping/vegetation that is required, other than grass, see 4.7.1.1.
- 4.7.1.4 In “Hillside Environments” all batters require specific design to the satisfaction of the Engineering Manager.
- 4.7.1.5 Where a batter is not required to cater for foot traffic, grassed batters are permitted, to a maximum of 1-in-4 (25%) to ensure they are mowable.

4.7.2 Support and Retaining Structures and Bridges

- 4.7.2.1 Stabilised faces, retaining structures or bridges that support private assets or property:
- Must be located outside of the legal road reserve. These faces and structures are the sole responsibility of the property owner whose land they support;
 - Will have certified design plans submitted to Council and a building consent, or exemption under Schedule 1 of the Building Act obtained.
- 4.7.2.2 Stabilised faces, retaining structures or bridges supporting the operation of the transport network must:
- Be located within the legal road reserve. This may require adjustment of the legal road boundary to ensure 1.0m minimum clearance from the toe or top of the wall or bridge structure to the boundary is vested to Council. If the structure is taller than 3.0m then 2.5m minimum clearance is required to be added to the road reserve to ensure Council can maintain and replace the structure in perpetuity. This greater area to vest may be provided by way of easement in favour of Council;
 - Have a design life of 80 years minimum;
 - Be designed in accordance with the NZTA Bridge Manual and have a design loading of HN-HO-72, unless the requirements of Appendix D of the NZTA Bridge Manual apply for lightly trafficked structures applies, then the design loading will be 0.85HN;
 - Be designed by and the construction supervised by a Chartered Professional Engineer (CP Eng) with producer statements PS1 and PS4 submitted to Council;
 - Have an engraved brass plaque fixed to the bridge showing its design loading;
 - To improve visual amenity retaining walls will be of the minimum height necessary;
 - Vegetated retaining walls including crib walls are not permitted;
 - Bridges will have a 500mm freeboard at Q100 -2100 flood levels and hydraulic evidence must be submitted to Council;
 - The design of all retaining structures supporting the transport network or areas likely to have buildings erected within the area between the wall and a line measured at 45 degrees to horizontal from the base of the wall, will include specific information from the Designer’s Professional Advisor (DPA). This information will include what design and construction methods will be implemented to ensure that future settlement of the ground behind the wall and the ground surface will be no greater than 20mm over a 6m horizontal length;
 - Design plans must be submitted to Council for comment prior to construction.

4.7.3 Geotechnical Risk Areas

- 4.7.3.1 In ground that may be subject to instability, including settlement as a result of severe seismic shaking causing liquefaction of the underlying subsurface materials the design of the transport system will be undertaken to the satisfaction of the Engineering Manager, by a Chartered Professional Engineer practising in geotechnical engineering and experienced in transport design. This includes but is not limited to Hillside Environments (Nelson), the Tahunanui Slope Hazard Area or Slope Instability Risk Areas (Tasman).
- 4.7.3.2 Consideration will be made with regard to transport design so as to avoid or mitigate against the possible effects arising from severe seismic ground shaking.

4.7.4 Sub-soil Drainage

- 4.7.4.1 Sub soil drains installed to for the purpose of dewatering retaining walls embankments, cuttings and the subgrade to supporting the construction on ongoing performance of the transport network will be wholly located within the road reserve.
- 4.7.4.2 Subsoil drains should comprise a minimum 110mm diameter slotted pipe surrounded with 100mm minimum of free draining drainage metal. Drains will be excavated into firm ground and will be linked together at a minimum grade of 1:250 and extended to connect into an approved stormwater system. Refer to NZTA F:2 specification for pipe subsoil drain construction for further detailed guidance.
- 4.7.4.3 Approved filter fabric material to NZTA F:7 specification will be placed between the drainage metal and in-situ or fill material.

Good Practice

The following matters provide additional guidance and direction regarding slope and stability design:

4.7.5 Hillside Construction

- 4.7.5.1 Roads should generally follow the natural contours of the land and should not be placed perpendicular to contour lines unless absolutely unavoidable. Curvilinear road alignments are preferred to influence a lower speed environment.
- 4.7.5.2 Cut and fill will be kept to a minimum to avoid earthworks altering the natural land form and avoiding removal of natural features, including vegetation.
- 4.7.5.3 A balance should be achieved between complying with design standards and minimising the adverse effects that excessive earthworks can create, such as visual pollution and high construction and maintenance costs.

4.7.6 Land Stability

- 4.7.6.1 Where in the opinion of the Council the stability of any embankment as planned is in doubt, then the Council may require a stability analysis of the slope, under saturated condition to be carried out (see also AS/NZS 1170: Structural Design Actions or the NZTA Bridge Manual).

4.7.7 Retaining Walls

4.7.7.1 Generally retaining walls should be constructed of either (or a combination of) the following types:

- a) Concrete cantilever with precast face;
- b) Concrete Pile Palisade;
- c) Concrete Pile Palisade with ground anchors;
- d) H6 Timber pole piles with timber lagging;
- e) H6 Timber pole piles, ground anchors and H5 timber lagging;
- f) Steel pole piles with H5 timber lagging;
- g) Steel pole piles, ground anchors, and H5 timber lagging;
- h) Galvanised wire, plastic coated mesh gabion.

4.7.7.2 Council may consider deviations from mandatory matters provided in the Land Development Manual for sites that are topographically constrained or to minimise the effects of earthworks.

4.7.7.3 The type of deviations that the Councils' may consider for hillside construction include:

- a) Providing narrower legal road widths. Wider widths may be impractical as it may be impossible to utilise more than a certain width due to crossfall restrictions. Private access may also be compromised if wide roads require high cuts or retaining walls;
- b) Provide for on-road parking in parking bays as an alternative to continuous kerbside parking lanes;
- c) Provide a lesser standard of elements, such as constructing only one footpath. Where only one footpath is provided it should generally be on the downhill side of the road;
- d) Locate pedestrian and cycle facilities separately from the carriageway.

4.8 Road Geometry

This section sets out requirements for the geometric design of road gradients, crossfall, elevations and safe stopping sight distances.

Mandatory Requirements

The following matters are requirements for the design of roads in terms of road geometry:

4.8.1 Gradients

4.8.1.1 Gradients are measured on the inside of any curves at the edge of the traffic lane.

4.8.1.2 Kerb grades will not be less than 1-in-250 (0.4%).

4.8.1.3 Road gradients will not be steeper than those values specified in Table 4-8.

Table 4-8 Maximum Road Gradients

Road Hierarchy	Maximum Gradient *
Arterial Roads	1-in-20 (5.0%)
Principal Roads	1-in-15 (6.7%)
Collector Roads	1-in-10 (10.0%)
Sub-Collector Roads	1-in-8 (12.5%)
Local Roads	1-in-7 (14.3%)
Residential Lanes	1-in-6 (15.8%)

* Gradients on bus routes will not be steeper than 1-in-15 (6.7%)

The average gradient (local roads and residential lanes) over 50m will not exceed 1-in-6 (16.7%)

4.8.2 Crossfall

- 4.8.2.1 The default normal crossfall of 1-in-33 (3%) in both directions from the crown will be developed on all standard sealed carriageways.
- 4.8.2.2 Where asphaltic concrete is used the crossfall will be no flatter than 1-in-50 (2%) unless on a curve associated with the application of super-elevation.
- 4.8.2.3 Where a uniform crossfall is developed from kerb-to-kerb, this will not be flatter than 1-in-50 (2%).
- 4.8.2.4 All stormwater from the carriageway and footpaths on roads and private ways will be collected by an approved stormwater system. Refer to Chapter 5 Stormwater, of the NTLDM for design and construction guidance on stormwater matters.

4.8.3 Super Elevation

- 4.8.3.1 Super-elevation is not required in areas with a speed limit of 60km/h or below.
- 4.8.3.2 On roads where the speed limit is over 60km/hr, specific design of super-elevation is required.

4.8.4 Horizontal curves

- 4.8.4.1 Curves on all classified roads and roads with a speed limit above 50km/h will be transitional.
- 4.8.4.2 Circular curves are permitted on unclassified roads with regulatory speed limits of 50km/h or less.
- 4.8.4.3 Horizontal curves in 50 km/hr zones must have a minimum centreline radius of:
- 80m for roads in the industrial zone;
 - 25m radius for Local Roads in residential areas and Residential Lanes with associated widening to the inner edge to enable large vehicles to safely negotiate curves in one pass; and;
 - 40m for roads in all other zones.

4.8.4.4 If reverse curves are necessary, they will have a design speed difference of no greater than 10km/h and be separate by a sufficient length of straight road to allow for development of super-elevation reversal at no greater than 2.5m/s/s (where the design speed is greater than 50km/hr).

4.8.4.5 Curves in the same direction (i.e. broken back) in close proximity are not permitted.

4.8.5 Safe Stopping Sight Distances

Safe Stopping Sight Distance (SSSD) is the distance required for a vehicle to safely stop between the time when the driver reacts to a conflict situation and the time the vehicle comes to rest.

4.8.5.1 Table 4-9 shows acceptable SSSD for various design speeds. For full details refer Austroads Guide to Road Design: Part 3 – Geometric Design, section 5.3.

4.8.5.2 SSSD is important in the design of 'Unclassified Roads' (roads that generally do not require a centreline to be marked) to ensure that sufficient visibility is provided between opposing vehicles on narrow carriageways to see each other and stop.

4.8.5.3 SSSD is also important to ensure adequate inter-visibility between transport users and to provide visibility to traffic management devices.

Table 4-9 Safe Stopping Sight Distance

Design Speed	Safe Stopping Sight Distance (m) $R_T = 2.0s^*$
≤ 30 km/h	25
40 km/h	40
50 km/h	55
60 km/h	73
70 km/h	92
80 km/h	114
90 km/h	139
100 km/h	165

* As required on level grade. Correction factors are to be applied on non-level roads in a manner that is consistent with Austroads Guide to Road Design: Part 3 – Geometric Design section 5.3. See Table 4-10 below.

Table 4-10 Corrections due to Grade - metres

Corrections due to grade	-8%	-6%	-4%	-2%	2%	4%	6%	8%
40 km/hr	5	3	2	1	-1	-2	-2	-3
50 km/hr	8	5	3	2	-1	-3	-4	-5
60 km/hr	11	8	5	2	-2	-4	-6	-7
70 km/hr	15	11	7	3	-3	-5	-8	-10
80 km/hr	20	14	9	4	-4	-7	-10	-13
90 km/hr	25	18	11	5	-5	-9	-13	-16
100 km/hr	31	22	14	6	-6	-11	-16	-20

4.8.5.4 SSSD is measured both in relation to vertical and horizontal curvature as illustrated in Figure 4-8.

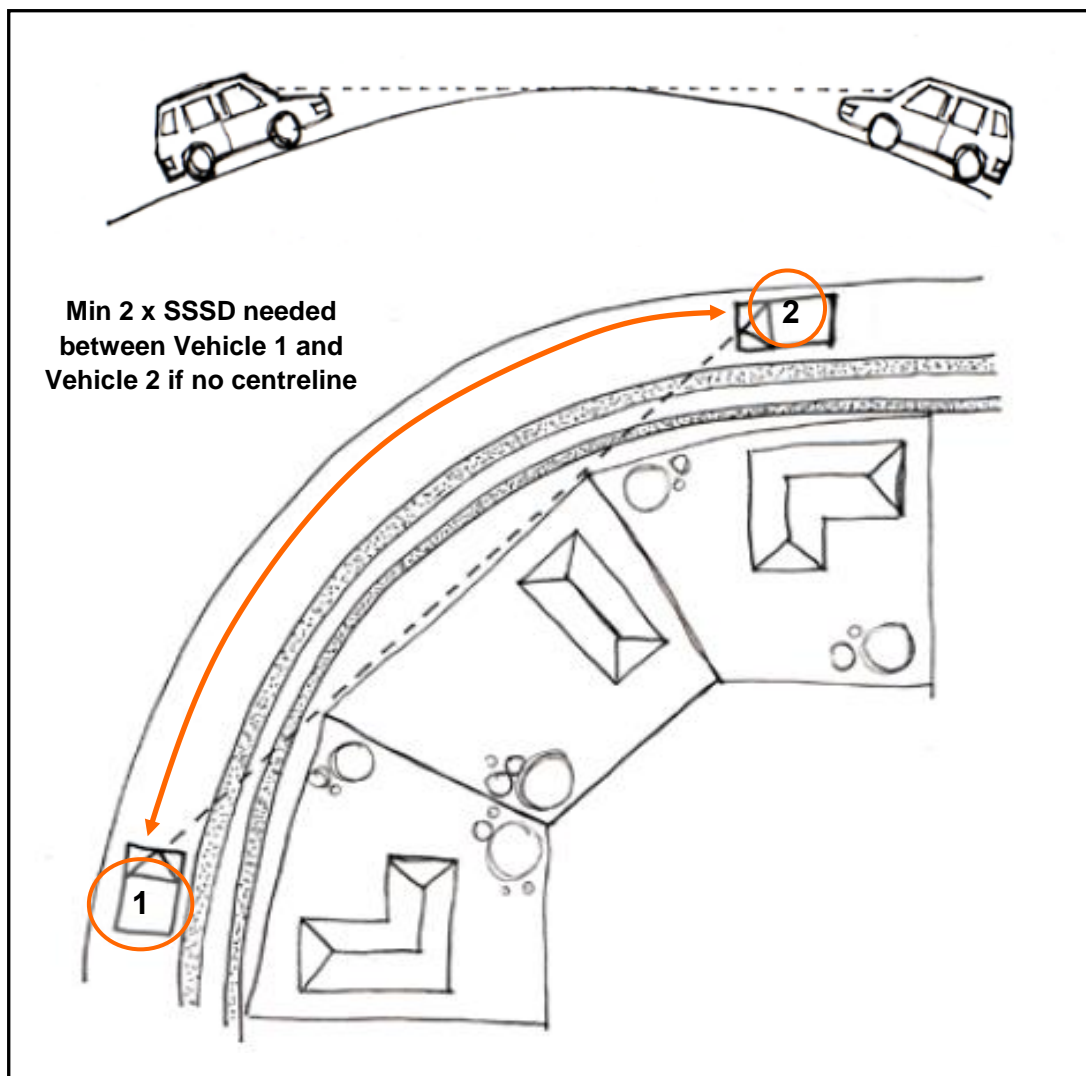

Figure 4-8 Measurement of Safe Stopping Sight Distance

4.8.5.5 On roads where two times the SSSD cannot be achieved, a centreline must be marked. This is likely to require the banning of kerbside parking and may require carriageway widening.

Good Practice

The following matters represents additional guidance and direction in regard to road geometry:

4.8.6 Gradients

- 4.8.6.1 At road intersections it is important that the crown of the intersecting road does not extend out into the carriageway of the through road, to maintain vehicle stability. Normally, this means running the crown of the minor road into the nearside edge of the main road lane line or quarter point.
- 4.8.6.2 Where the kerb levels differ for design purposes, crossfalls varying from 1 in 50 (2%) to 1-in-20 (5%) from the crown may be permitted, coupled with a lateral shift in crown position of up to one quarter of the carriageway width.
- 4.8.6.3 Council will consider steeper gradients on a case-by-case basis and these may be permitted over short lengths, but the Council reserves the right to impose special conditions of construction. Grades should be as long as possible and vertical curves provided at all changes of grade.

4.8.7 Super-Elevation

- 4.8.7.1 In 'Hillside Environments' super-elevation may be employed where it suits boundary levels up to the allowable design maximum crossfall of $\pm 6\%$.

4.8.8 Kerb Lines

- 4.8.8.1 Kerbs should be at the same level on both sides of the road however in some circumstances, the left and right-hand kerb lines may be better graded individually in conjunction with centre line levels, footpath levels and boundary levels. Under such circumstances, at a given cross section, the left and right-hand kerbs maximum difference in kerb level = 120mm + 15mm/m for roads with a carriageway wider than 7.0m.

4.9 Intersection Design

This section provides standards and guidance on matters relating to intersection design.

Mandatory Requirements

The following matters are required in the design of intersections:

4.9.1 General

- 4.9.1.1 Intersections will be designed to improve the legibility of the transport network and reinforce the function of the intersecting roads as defined by the road hierarchy.
- 4.9.1.2 The design of unsignalised and signalised intersections will be in accordance with Austroads Guide to Road Design Part 4A – Unsinalised and Signalised Intersections.
- 4.9.1.3 The design of roundabouts will be in accordance with Austroads Guide to Road Design Part 4B – Roundabouts.

- 4.9.1.4 The design of cycle facility intersections will be in accordance with NZTA's Cycling Network Guidance and Austroads Guide to Road Design Part 6A Paths for Walking and Cycling.
- 4.9.1.5 The road marking and sign layout at all intersections types will be in accordance with the NZTA Manual of Traffic Signs and Markings (MOTSAM) and NZTA Traffic Control Devices Manual.
- 4.9.1.6 Intersections will not be designed to be a stop control.

4.9.2 Sight Distances

- 4.9.2.1 Safe Intersection Site Distance (SISD) is the minimum sight distance that should be available from intersection legs with priority to vehicles which could emerge from non-signalised legs. It is measured along the carriageway from the approaching vehicle to the conflict point. For full details refer Austroads Guide to Road Design: Part 4A – Unsignalised and Signalised intersections, section 3.2.
- 4.9.2.2 SISD is the distance required for the driver of a vehicle on the main road to observe a vehicle entering from a side road, decelerate and stop prior to a point of conflict. It is also generally sufficient to enable cars to cross a major road from a side road safely.
- 4.9.2.3 SISD is viewed between two points 1.15m above the road surface. One point is the driver's eye height on the leg with priority and the other represents eye height of a driver in the side road. The driver in the side road is assumed to sit at a distance of 3.0 minimum from the lip of the kerb or edge line projection of the major road.
- 4.9.2.4 SISD allows for a 3.0 second observation time for a driver on the through leg of the intersection to detect the problem ahead for example; car from minor road stalling in through lane, plus Safe Stopping Sight Distance (SSSD).
- 4.9.2.5 SISD is to be provided in accordance with Table 4-11.

Table 4-11 Safe Intersection Sight Distance

Speed Environment	Safe Intersection Sight Distance (m) $R_T = 2.0s^*$
≤ 30 km/hr	50
40 km/hr	73
50 km/hr	97
60 km/hr	123
70 km/hr	151
80 km/hr	181
90 km/hr	214
100 km/hr	285
110 km/hr +	324

*As required on level grade. Correction factors are to be applied on non-level roads in a manner that is consistent with Austroads Guide to Road Design: Part 4A – Unsignalised and Signalised Intersections, see Table 4-12 below.

Table 4-12 Grade corrections to ASD and SISD (cars)

Design speed (major road) (km/h)	Correction (m)							
	Upgrade				Downgrade			
	2%	4%	6%	8%	2%	4%	6%	8%
40	-1	-2	-2	-3	1	2	3	5
50	-1	-3	-4	-5	2	3	5	8
60	-2	-4	-6	-7	2	5	8	11
70	-3	-5	-8	-10	3	7	11	15
80	-4	-7	-10	-13	4	9	14	20
90	-5	-9	-13	-16	5	11	18	25
100	-6	-11	-16	-20	6	14	22	31

4.9.3 Kerb Radii

4.9.3.1 Kerb radii at intersections will be small enough to:

- a) Provide pedestrian desire lines that are as straight as possible;
- b) Encourage low speed left turn movements;
- c) Enable an RTS-14 compliant tactile paver layout to be provided.

4.9.3.2 Tracking paths on public roads will be designed in accordance with RTS 18 New Zealand “on road tracking curves for heavy vehicles” 2007. Kerb radii at intersections will be large enough to accommodate the turning requirements of the design vehicle as follows:

- a) For turns at intersections where both roads are ‘Classified Roads’ the 18m design semi-trailer with turning path radius of 12.5m, without crossing the centreline of the road being entered;
- b) For turns between a ‘Classified Road’ and an ‘Unclassified Road’ the 18m design semi-trailer with turning path radius of 12.5m, using any part of the ‘Unclassified Road’ carriageway, and the correct side of the ‘Classified Road’ carriageway;
- c) For turns at intersections where both roads are ‘Unclassified Roads’ in residential and rural lifestyle zones, the design medium rigid truck with turning path radius of 10m using any part of the carriageway;
- d) For turns at intersections where both roads are ‘Unclassified Roads’ in Commercial and Industrial zones, the 18m design Semi Trailer with a turning radius of 12.5m using the correct side of the approach road intersection and any part of the carriageway being entered;
- e) For turns between all public roads, the 85th percentile design car with a minimum turning path radius of 5.8m, using the correct side of the two carriageways;
- f) Council may require intersections to be designed for a larger vehicle if larger vehicle movements are expected.

- 4.9.3.3 Consideration must always be given to narrowing the width of the carriageway at intersections with kerb extensions to keep pedestrian crossing distances to a minimum and control turning vehicle speeds while allowing for safe passage by cyclists.
- 4.9.3.4 An inside kerb radius of 5m is typically required at kerb extensions to facilitate street cleaning.
- 4.9.3.5 Outside Kerb radii will not be less than 3.0m.

Good Practice

The following matters can provide additional guidance and direction in the design of intersections:

4.9.4 General

- 4.9.4.1 Priority intersections promote movements on higher order roads over lower order roads and that principal will guide the road hierarchy layout.
- 4.9.4.2 The geometry of any road intersection should be designed so that the major route is the through road and has traffic priority. Wherever the roads are of equal classification, traffic volumes and the nature of upstream and downstream intersections will inform the decision of which approach is provided with priority. In some circumstances it may be appropriate to control these intersections with a higher form of control such as a roundabout or traffic signals.
- 4.9.4.3 As priority intersections do not afford any priority to pedestrians, consideration should be given to providing traffic calming or physical crossing aids to improve pedestrian crossing opportunities. This may be achieved through the use of facilities such as kerb extensions, intersection threshold platforms, raised medians and pedestrian islands.

4.9.5 Four Way Intersections

- 4.9.5.1 To improve connectivity in local residential areas Council will consider the use of priority controlled four-way intersection in residential areas where all intersecting roads are 'Unclassified Roads'. The site should have an approach speed environment of no more than 30km/h and where the total number of vehicles passing through the type of intersection not exceeding 1,200 vehicles per day total on all arms at full development. Where higher traffic volumes are anticipated, the intersection should be controlled with a roundabout or the intersection redesigned as a three-leg T-intersection.

4.9.6 Roundabouts

- 4.9.6.1 Roundabouts should be designed to ensure low entry and exit speeds. For safety reasons, it is important that comparable levels of visibility to the right are provided on all approaches to ensure that the entry speed of vehicles on any one approach is not substantially different from other approaches.
- 4.9.6.2 The preferred form of roundabouts at intersections in residential zones incorporates a semi-mountable apron so that through vehicle speeds can be managed whilst still providing for the larger turning requirements of vehicles such as buses, waste collection and emergency vehicles. Conventionally designed roundabouts with comparatively large central islands and approach deflection are generally not appropriate in residential areas. Their capacity advantages are not usually applicable in these lower traffic volume situations.

- 4.9.6.3 When considering installing multi-lane roundabouts, walking and cycling needs to be carefully considered as generally multi-lane roundabouts sever active transport access unless there are specific grade separated facilities for those users.
- 4.9.6.4 Roundabouts can have a negative impact on walking and cycling in higher volume situations as they are inconvenient for pedestrians, deflected from their desire lines, and people waiting to cross one of the arms may not be able to anticipate easily the movement of all motor vehicles on the roundabout, or those entering or leaving it.
- 4.9.6.5 Roundabouts can be designed to benefit pedestrians, as follows:
- Splitter islands that incorporate pedestrian island crossing facilities;
 - Approaches and departures can be combined with kerb extensions to reduce crossing distances and reduce vehicle speeds;
 - By providing pedestrian platforms where the speed environment on an approach is less than 50 km/h.
- 4.9.6.6 Roundabouts can create problems for the vision impaired pedestrians due to confusing auditory signals from approaching and circulating vehicles.
- 4.9.6.7 Roundabouts can be hazardous for cyclists. Drivers entering at relatively high speed may not notice cyclists on the circulatory carriageway, and cyclists travelling past a leg are vulnerable to being hit by vehicles entering or leaving the intersection.

4.9.7 Traffic Signals

- 4.9.7.1 At busy junctions requiring multiple approach lanes and with high numbers of active users, traffic signals are generally preferred over roundabouts.
- 4.9.7.2 The primary factor in proposing use of traffic signals has to do with the availability of safe gaps. If the gaps in the major street flow can safely accommodate entering traffic from side streets for the majority of the time, it is reasonable to assume that traffic signals are not required. However, as vehicle volumes increase, the likelihood of having to provide traffic signals increases.
- 4.9.7.3 Traffic signals are a safe method for active users to cross the road. This is heightened when young, or elderly pedestrians are involved.

4.10 Private Access and Crossings

This section outlines design standards and guidance for access to and from property to roads, including crossings.

Mandatory Requirements

These standards are required in the design of private accesses and crossings:

4.10.1 General

- 4.10.1.1 When designing private accesses, the long-term maintenance costs for the residents must be balanced against the benefits of providing access through a public road.
- 4.10.1.2 The design and construction standards, including drainage for private access must comply with the requirements for an equivalent construction of a public road, including the 50-year design life.
- 4.10.1.3 The footpath and any cycle facility will be continuous across private driveways and private access to ensure priority to footpath and cycle facility users is reinforced.
- 4.10.1.4 The private access will provide for utility services.

4.10.2 Private Access

4.10.2.1 Private access must:

- a) Be designed in accordance with the minimum specifications in Table 4-13;
- b) Only serve up to six residential units or dwellings, commercial or industrial units;
- c) Give access to the lower ranked road in the hierarchy if the site has frontage to more than one road;
- d) Not create a shorter through-route alternative for vehicles, cycles or pedestrians than the adjoining road network;
- e) Intersect with the carriageway at an angle of 90 degrees on classified roads i.e. arterial, principal or collector, and between 75 and 105 degrees on unclassified roads;
- f) Be located at least 1.0m from any side boundary to allow the placement of telecom and power distribution pillars and boxes.
- g) In the case of adjacent property owners in any zone wishing to have a mutual crossing at their shared boundary, the maximum permitted total length of the crossing shall be 8.0m
- h) Mutual crossings at shared boundaries will need specific design and application to Council.

Table 4-13 Private Access and Crossing Width

Zone	Number of Units /Users ¹	Min. Carriage way Width ²	Footpath	Min. Legal Reserve Width	Gradient ³	Surface ⁴	Extension of Carriage way Surface ⁵	Crossing Width at Road Edge/Kerb ⁶
Residential	1	2.75m	-	-	1-in-5 ³	All Weather ⁴	5m ⁵	3.5 - 6m
	2 to 3 ¹	2.75m	-	4.5 ² m	1-in-5 ³	Sealed	Full length	3.5 - 6m
	4 to 6 ¹	2.75m	-	4.5 ² m	1-in-5	Sealed	Full length	3.5 - 6m
Commercial, Central Businesses, Tourist Services etc.	1	4.5m	-	6.0m	1-in-8	Sealed	Full length	5 - 7m
	2-6 ²	4.5m	1.5m	6.5m	1-in-8	Sealed	Full length	5 - 7m
Industrial & Rural Industrial etc.	1	4.0m	-	-	1-in-8	Sealed	Full length	6 - 8m
	2-6	6.0m	-	8.0m	1-in-8	Sealed	Full length	6 - 8m
Rural Lifestyle, Rural Industrial etc.	1	2.75m	-	-	1-in-5 ³	All Weather ⁴	10m	6 - 8m
	2-6	3.0m	-	5.0m	1-in-5 ³	All Weather ⁴	10m	6 - 8m
Rural 1, 2 & 3	1 ¹	2.5m	-	-	1-in-5 ³	All Weather ⁴	10m	6 - 8m
	2-6 ¹	2.5m	-	6.0m	1-in-5 ³	All Weather ⁴	10m	6 - 8m

1 Means any discrete household unit/dwelling or business unit.

2 Where a shared private access in all zones is more than 50m long, a passing bay will be provided (at the start of the Row Tasman District and) at least once every 50m (see 4.10.2.5).

3 Gradients up to 1-in-4.5 can be used on straight lengths over distance of up to 20m. See also 4.10.3 (transition grades).

4 Sealed surface if grade is 1:5 or steeper.

5 Where the proposed private access way is designed with a legal reserve width of 4.5m or less, more detailed design information will be required to satisfy the Council that the specific design provisions will operate satisfactorily. Designers should note that these widths will make turning into and out of properties difficult so careful detailed design will be needed.

6 Refer SD407 for urban vehicle entrance plan and SD409 for rural vehicle entrance plan.

- 4.10.2.2 Where the speed limit is over 60km/h the crossing must comply with:
- a) For a private access serving up to six dwellings (weather or not on the same site) SD409. The grade of the crossing will be more or less level ($\pm 6\%$) for the first 6m from the carriageway;
 - b) For a private access serving more than six dwellings or a rural activity (including sales from a rural property) SD409. The grade of the crossing and the access it joins will be more or less level ($\pm 6\%$) for the first 20m from the carriageway;
 - c) For a private access serving a commercial or industrial activity SD409. The grade of the crossing and the access it joins will be more or less level ($\pm 6\%$) for the first 20m from the carriageway;
- 4.10.2.3 Not more than one crossing is provided per site. Except to facilitate on-site turning and a one-way traffic flow in Commercial and Industrial zones through a site fronting a road with a speed limit of 50 kilometres per hour or less, provided there is at least 7.5 metres between accesses on the same road frontage, and one access is marked "in" and the other "out".
- 4.10.2.4 Where a crossing from a Classified Road gives access to a car parking area containing more than 20 spaces, a queuing area at least 15 metres long will be provided for vehicles entering and leaving the site. The queueing area length is measured from the road boundary of the site to the first point at which a vehicle can turn into a parking space or aisle.
- 4.10.2.5 Passing Bays - any passing bay will be constructed to a minimum width of 5.5m (includes carriageway) and have a minimum length of 6.0m with a 4.0m long taper at each end.
- 4.10.2.6 Vehicle Gates - any gate or door will be hung to open into the site, and is set back sufficiently to ensure that the largest class of vehicle likely to need access to the site on a regular, frequent or predictable basis can be stopped off the road carriageway while the gate is being opened or shut.
- 4.10.2.7 Culvert Diameter - the minimum diameter of culverts under driveways where the driveway crosses a road swale drain will be 375mm diameter. Note: this shall also address secondary flow paths so that they are contained within the swale.
- 4.10.2.8 The 'Extension of Carriage way Surface' shown in Table 4-13 is measured from road edge and shall be concrete or match the footpath surface where one exists except:
- a) In industrial zones when it will be concrete;
 - b) Where a chip seal footpath exists in non-industrial zones when it will be asphaltic concrete.
- 4.10.2.9 The berm or shoulder adjacent to a private access with more than one user will be designed to incorporate collection areas for waste and recycling wheelie bins without blocking the footpath. The collection area will be 1.0m² for each property accessed from the private access.

4.10.3 Gradients

Critical aspects of private access design and crossings in relation to gradient are set out in Table 4-13 with details on transitions shown in SD406 to SD409 and Figure 4-119.

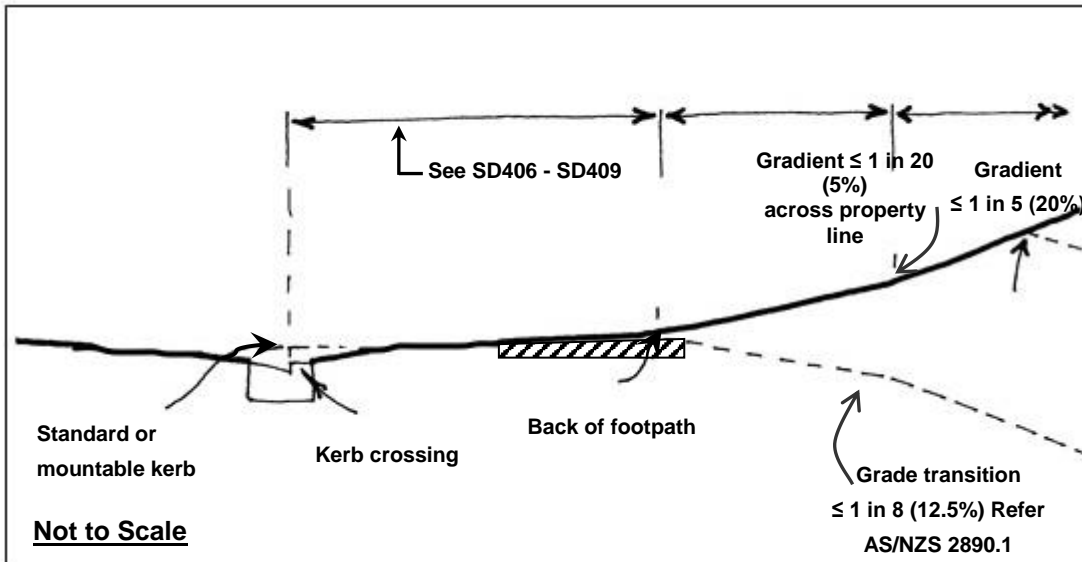

Figure 4-9 vehicle entrance grade transitions Grade changes are required to ensure vehicles will not scrape their undersides. Grade transitions of 2.0m long are required whenever the ramp grade changes by more than 12.5%. Refer to 'AS/NZS 2890.1:2004 Parking facilities – Part 1: Off-street car parking' for detailed design guidance.

4.10.3.1 Gradients of an access that crosses a footpath shall generally be as shown in SD's 406, and 407.

4.10.3.2 Except as specifically provided for in the standards of this sub-section, the maximum gradient of an access ramp for the first 6m from the property boundary line will be 1-in-20 (5%). Where the following conditions are met, the grade can be increased to 1-in-8 (12.5%) for the first 6m:

- a) The ramp is a downgrade for traffic leaving the property; and
- b) The vehicular access is to an 'Unclassified Road'.

4.10.3.3 On roads where the footpath is located against or close to the kerb and where the target speed environment is 40km/h or lower, vehicle crossings will be designed with a mountable kerb.

4.10.4 Sight Distances (other than Safe Intersection Site Distance)

4.10.4.1 Vehicle Access Sight Distance - sight distance is measured from the motorist's position at the access point (2.5m back from the edge of the carriageway and at a height of 1.1 metres) in both directions along the frontage road. Where the frontage road is one-way or is median divided, the sight distance is only required in the direction of approaching and potentially conflicting traffic movements.

The minimum sight distance that must be available from any vehicle access point along the frontage road is shown in Table 4-14.

Table 4-14 Minimum Sight Distance from Private Vehicle Access Points

Speed Environment *	Minimum Sight Distance (m) $R_T = 2.0\text{sec}$
≤ 30 km/hr	23
40 km/hr	40
50 km/hr	55
60 km/hr	73
70 km/hr	92
80 km/hr	114
90 km/hr	139
100 km/hr	165
110 km/hr +	193

*If the speed environment is not known, the speed environment will be taken as 10km/h above the regulatory speed limit for the purposes of determining minimum sight distances. Based on Austroads Guide to Road Design Part 4A: Approach Sight Distance Table 3.1.

Upgrade/downgrade corrections will be applied in accordance with Austroads Guide to Road Design Part 4A: Table 3.3.

4.10.5 Visibility Splays

4.10.5.1 For all vehicle access points, a minimum visibility splay with the dimensions shown in Figure 4-10 must be provided. Items may be located within the visibility splay provided they do not obstruct visibility to pedestrians. Generally, this means avoiding objects and vegetation with a height of more than 0.9m.

4.10.5.2 For high volume or high safety risk vehicle access points including:

- a) Commercial and Industrial zones;
- b) Vehicle oriented activities¹ with daily volumes in excess of 50 movements;
- c) Where there is a cycle facility² less than 3.0m from the property boundary.

The minimum visibility splay with the dimensions shown in Figure 4-11 must be provided.

If the access is adjacent to a neighbouring property, the access may need to be moved away from the common boundary to comply with sight visibility. The legal easement width may need to be adjusted accordingly.

¹ Vehicle orientated activities includes; Service Stations, Truck Stops, Supermarkets, Malls, Drive In/Drive through, Detail Outlets.

² Cycle facility = cycleway/shared path.

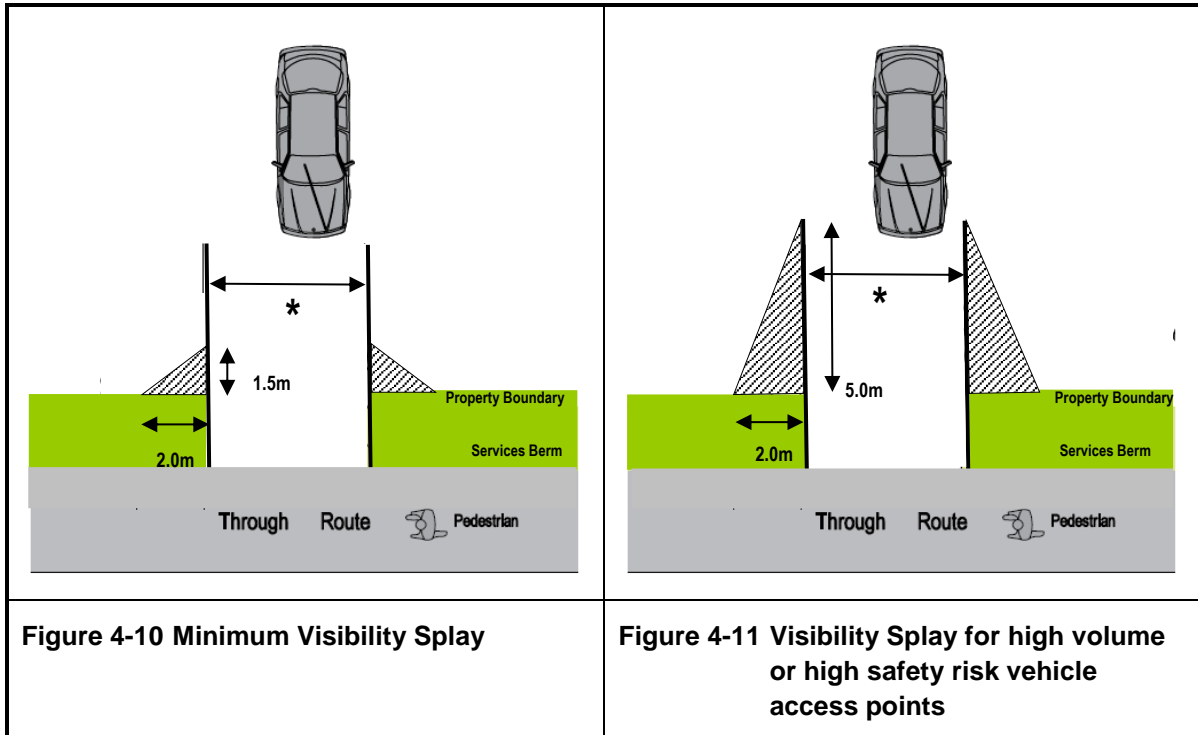

* Carriageway width in accordance with Table 4-13.

4.10.6 Tracking Paths

- 4.10.6.1 Except for a single dwelling that has access from a 'Unclassified Road' with a regulatory speed limit of 50km/h or below; the site will provide manoeuvring space for the largest class of vehicle likely to need access to the site on a regular, frequent or predictable basis, so that a vehicle does not need to reverse to or from the road. The manoeuvring will use no more than three individual movements to allow vehicles to enter and exit a site.
- 4.10.6.2 Tracking paths and turning circles on private land will be provided in accordance with ASNZS 2890.1 "off-street carparking" 2004.
- 4.10.6.3 Vehicle access points must be located so that no part of the access, nor tracking path crosses any part of another site except where there is a right of way or other similar legal easement over those parts of the other site. See Figure 4-12.

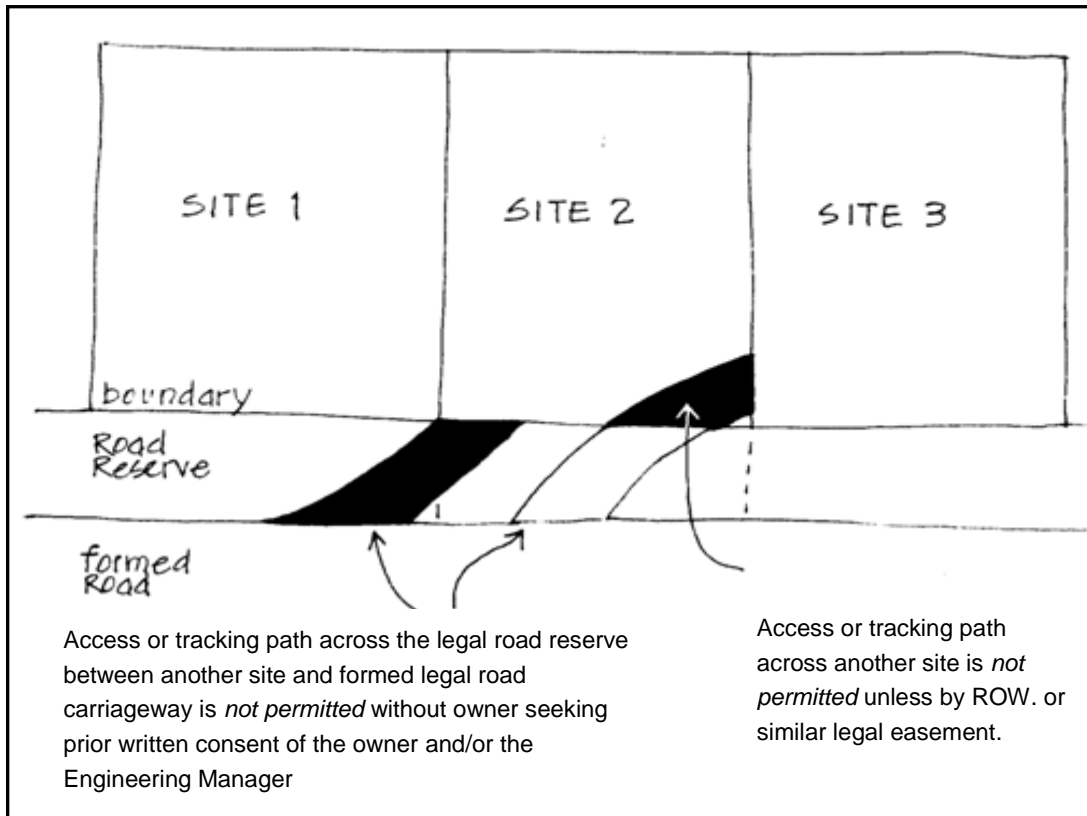

Figure 4-12 Tracking Paths and Access- Steep hillsides only

4.10.7 Minimum distance of a vehicle crossing from intersections

4.10.7.1 No part of a vehicle crossing shall be closer to a road intersection than the distances permitted in Table 4-15 Except when the boundaries of the site do not allow, then a single vehicle crossing may be constructed provided it is located adjoining an internal boundary of the site in the position which most nearly complies with the provisions of on the road ranked lower in the road hierarchy (applies to corner sites).

Table 4-15 Minimum Separation Distance of Vehicle Access from Intersections and private access crossings – metres (see also Fig 4-3)

Access from Frontage Road	Intersecting Road or private access crossing		
	Arterial (m)	Principal/Collector (m)	Unclassified/Private access (m)
Speed Limit up to 50km/h			
Arterial	60	Not Permitted	Not Permitted
Principal/ Collector	50	35	Not Permitted
Unclassified	30	24	10
Speed Limit between 51 and 79km/h			
Arterial	110	Not Permitted	Not Permitted
Principal/ Collector	85	70	Not Permitted
Unclassified	60	50	40

Access from Frontage Road	Intersecting Road or private access crossing		
	Arterial (m)	Principal/Collector (m)	Unclassified/Private access (m)
Speed Limit between 80 and 100km/h			
Arterial	170	Not Permitted	Not Permitted
Principal/ Collector	125	100	Not Permitted
Unclassified	80	70	60

Notes

Distances will be measured along the boundary parallel to the centreline of the road from the kerb or formed edge of the intersecting road/Private access.

- 4.10.7.2 For sites with frontage to a Classified Road; arterial, principal, collector where the speed limit is 80km/h or higher, the minimum spacing between successive accesses on either side of the road will be 200 metres both within sites and between adjacent sites.

Good Practice

The following matters can provide additional guidance and direction in the design of private access and crossing design:

- 4.10.7.3 The number of access points along all roads will be minimised, to avoid:

- a) Conflict points with people walking and cycling on shared paths and footpaths.
- b) A reduction in berm that is available for landscaping, street trees and street furniture, thereby reducing the amenity of the road environment;
- c) A reduction in the amount of on-road parking that is available.

- 4.10.7.4 For residential lots, consideration should be given to the likely position and orientation of future garaging/parking spaces on the lot when deciding on the location of the vehicle access point. This is needed to reduce the likelihood of the access having to be shifted or widened at a later date.

- 4.10.7.5 Continuous vehicle access points may be used within the turning head of a cul-de-sac provided the footpath is offset from the carriageway by at least 1.5m.

- 4.10.7.6 Where 4.10.6.3 cannot be achieved, Council may consider private access over any part of the legal road to which an adjoining property has frontage where the written consent of the owner of the other site and/or the Engineering Manager has been obtained (see Figure 4-12).

- 4.10.7.7 Private access should be designed for good passive surveillance into and along its length.

4.11 Clear Zones

The purpose of a clear zone is to provide space for the driver of a vehicle that leaves the traffic lane to regain control while sustaining minimum damage to the vehicle and its occupants. This section outlines requirements and guidance for the design of them.

Mandatory Requirements

The following standards are required for the design of clear zones within the transportation network:

4.11.1 General

- 4.11.1.1 A clear zone must be measured from the edge of the traffic lane and is the width of roadside available for the driver to undertake corrective action and may include the cycle facility and footpath width.
- 4.11.1.2 Where it is not possible to provide an adequate clear zone, free of non-frangible obstacles for the appropriate distance, a vehicle barrier will be erected.
- 4.11.1.3 Any vehicle barrier within the clear zone, must include the barrier deflection when determining the offset between the edge line and the hazard. Guidance on the design and construction of vehicle barriers will comply with NZTA M23 Notes 'Notes for Road Safety Barrier Systems' (2009).
- 4.11.1.4 Hazards within the clear zone also include vertical drops from features such as drains and culverts. Any vertical drop of more than 1m within the clear zone will be considered to be a hazard. The hazard must be removed or treated to prevent the vehicle going over the drop. A vehicle barrier is likely to be the most common form of treatment.
- 4.11.1.5 To provide this zone, potential non-frangible hazards such as above ground utilities, street furniture, street trees and lighting columns will be located at a distance from the edge of the traffic lane greater than the widths shown in Table 4-16.

Table 4-16 Clear Zone Widths (With Kerb)

Road Hierarchy	Speed Environment		
	≤ 50km/h	70km/h	100km/h
Arterial	2.5	5.4	9
Principal	2.0	5.4	9
Collector	1.5	3.4	9
Sub-Collector	1.0	3.4	6
Local	0.5	3.4	6
Residential Lane	NA	NA	NA

Good Practice

Additional guidance and direction about the design of clear zones is provided below:

4.11.2 General

4.11.2.1 To be regarded as part of the clear zone the areas should be:

- a) Relatively flat, with a maximum side slope of 1-in-3 (cutting) and desirably 1-in-4 (embankment) or flatter; and
- b) Traversable, having slope changes that will keep all wheels of a vehicle in contact with the ground (this assists the vehicle driver to regain control).

4.11.2.2 Only objects which are designed to collapse or break away on impact should be located in the clear zone to ensure minimal damage to a vehicle and its occupants.

4.12 Parking (on street/road)

This section provides standards for the design of parking spaces and car parks (including accessible car parks).

Mandatory Requirements

The following matters are required in the design of parking:

4.12.1 General

Parking is required in accordance with the requirements in Table 4-6 and Table 4-7. If indented bays are used, they will be at least 2.2m wide and no wider than 2.5m.

4.12.1.1 One carpark per two lots is the default on street carpark requirement on 'Unclassified' roads if angled or inset car park bays are provided. Where all the following conditions exist one carpark per three lots can be provided:

- a) Onsite parking requirements are met;
- b) 50% or more of lots are greater than 600m²;
- c) Development is not in a 'Hillside Environment'.

4.12.1.2 Parking bays to be evenly distributed along the road at no greater spacing than 50m.

4.12.1.3 Parking spaces will commence a minimum distance of 6.0m from any side road and no closer than 1.0m to any access.

4.12.1.4 Where parking is metered, restricted or angled individual parking spaces will be marked.

4.12.1.5 Marking is required for all parking start and end points on Arterial, Principal and Collector Roads in Nelson.

4.12.1.6 Where angle parking is used on roads classified as sub-collector roads or higher, clear space must be available for vehicles to manoeuvre to and from spaces completely clear of the live traffic lane.

4.12.1.7 Angle parking is only appropriate on roads where the speed limit is 50km/hr or less.

4.12.1.8 The dimensions of angle parking spaces on street will be in accordance with Parking Standard AS 2890.5.

Good Practice

The following matters provide additional guidance and direction in the design of car parking:

4.12.1.9 Parking should be designed as part of the road design, although it is not always a requirement.

4.12.1.10 On-road parking should be designed to ensure convenient access to frontages and add to the transport amenity.

4.12.1.11 Parking bays may be used to break up the visual impact of on-road parking through separating small groups of parking spaces by kerb extensions, street furniture and planting. The resulting kerb extensions then generally provide more and safer opportunities for pedestrians to cross at mid-block locations and contribute to better overall road environment amenity.

4.12.1.12 An appropriate level of on-road parking may be provided in respect of the following:

- a) The nature of the surrounding land use;
- b) The function and geometry of the road;
- c) The amount of off-road parking provided;
- d) The total amount of parking expected to be generated;
- e) The turnover rate of parking that is anticipated.

4.12.1.13 When designing parking, the following benefits should be considered:

- a) In residential areas, parked vehicles create the perception of a narrower carriageway, which is likely to reduce vehicle speeds;
- b) Parked vehicles can provide a barrier between traffic lanes and the footpath and or cycle facility;
- c) That they provide a common resource, catering for residents, visitors, customers and service vehicles in an efficient manner;
- d) Able to cater for peak demands from various users at different times of the day;
- e) Introduces activity to the road environment.

4.12.1.14 When designing parking, the following matters should be taken into account:

- a) On narrower roads, there may be a tendency for vehicles to park on footpaths restricting pedestrian movement;
- b) On-road parking spaces can visually dominate the road scene and undermine speed objectives, particularly when parking demand is low;
- c) Safety issues may arise for active users if high parking demand reduces the availability of crossing opportunities with adequate visibility;

- d) Safety issues may arise for active users if high parking demand and adequate inter-visibility between the through traffic and the cycle and footpath facilities is not provided at private accessways;
- e) Cars parked on-road can be more vulnerable to opportunistic crime than off-road parking spaces;
- f) Angle parking on Local roads may be designed so that vehicles manoeuvre to and from spaces using the live traffic lane;
- g) Reduction in the volume of stormwater runoff from on street car park areas is encouraged by using permeable paving. The permeable surface must a permanent non-frittering surface. Excess stormwater in the base layers will be controlled so it does not saturate the carriageway layers by either, ensuring the grades and cross falls of the base materials direct excess stormwater away from the carriageway or a subsoil drain intercept is connected to the nearest sump. Acceptable solutions include permeable concrete segmental pavers;
- h) The crossfall of parking bays should be designed to have them drain towards the road unless they have a permeable surface. The width of any dish channel may be included as part of parallel parking width dimensions.

4.13 Public Transport, Footpaths, Public Accessways and Cycle Facilities

This section deals with the design of the transport network for pedestrians, cyclists and public transport.

Mandatory Matters

These standards are required for the design of the transport system for pedestrians, public transportation and cyclists:

4.13.1 Safety from Falling

- 4.13.1.1 Where people could fall 1 metre or more (except in remote locations where the route served presents similar natural hazards) a hand rail will be provided.
- 4.13.1.2 Where a handrail is located adjacent to public roads the handrail will comply with SD420 to SD424.
- 4.13.1.3 In other environments, such as private accesses, the balustrade may comply with the alternative design as in SD419.
- 4.13.1.4 If the designer wishes to erect a balustrade of alternative design to the two above, then full details will be submitted to the Engineering Manager for approval.
- 4.13.1.5 For barrier details of relevant to footpaths refer to Table 4-17 and for cycle facilities refer to Austroads Guide to Road Design Part 6A: Paths for Walking and Cycling - section 5.5.3.

4.13.2 Public Transport

- 4.13.2.1 The development of urban land and design of transport networks must design for the convenient access of public transport.

4.13.3 Footpaths

- 4.13.3.1 The design of footpaths will be in accordance with the requirements of the NZTA Pedestrian Planning and Design Guide.
- 4.13.3.2 The number and width of footpaths are specified in Table 4-6 and Table 4-7 that are to be provided in various planning zones. The widths specified in Table 4-6 and Table 4-7 and are 'Through Route' widths that must be free of all obstructions such as vegetation, light columns, signs, utility furniture, bollards etc.
- 4.13.3.3 Where objects are located adjacent to a footpath a pedestrian will tend to 'shy away' from those objects. In order to ensure 'Through Route' widths are maintained, the minimum footpath width will be increased by 150mm where such an object is present on one side and by 300mm where objects are present on both sides. Refer to Figure 4-13 for widening detail for footpaths of 1.5m through width.
- 4.13.3.4 Where any footpath is located directly against the property boundary it must have a minimum width of 1.65m. Where a footpath is located against a kerb, the width of the footpath excludes the top of the kerb. Refer to Figure 4-13 for widening detail for footpaths of 1.5m through width.

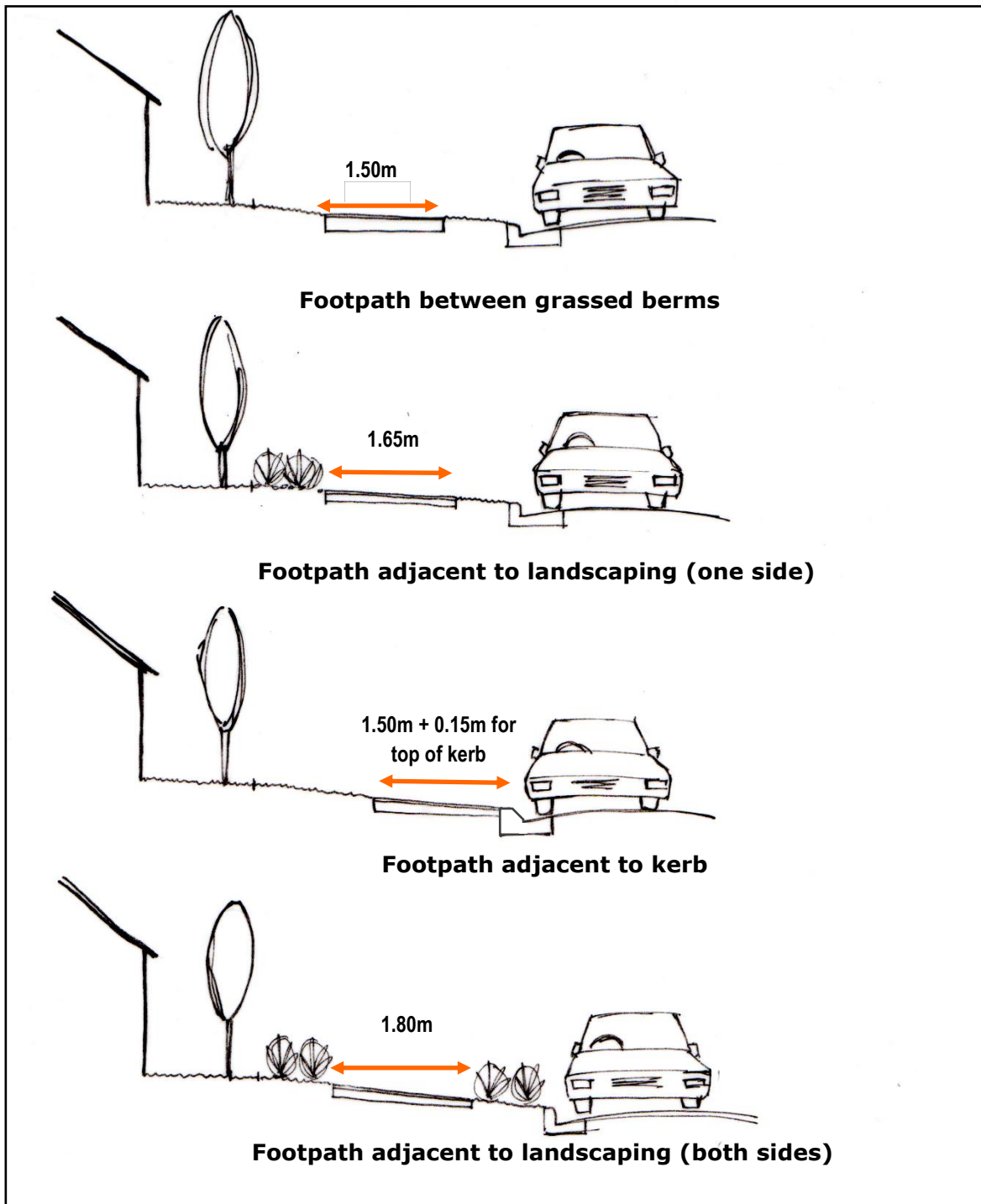

Figure 4-13 Minimum Footpath Widths for Through Width of 1.5m

- 4.13.3.5 In residential areas, footpaths will be separated from the carriageway by a berm, or cycle facility.
- 4.13.3.6 All footpaths in the “Hillside Environments” require specific design to the satisfaction of the Engineering Manager.
- 4.13.3.7 Critical aspects of footpath design specified in this guide that must be adhered to are presented in SD406 and SD407.

Table 4-17 Critical Aspects of Footpath Design

Design Aspect	Design Requirement
Gradient	<p>The mean gradient (change in vertical elevation between the top and bottom of a footpath) on any footpath should not exceed 5%.</p> <p>The maximum gradient (change in vertical elevation measured at 0.6m intervals along a footpath) will not exceed 8% for a continuous distance of 9m.</p> <p>Where one or both are unavoidable, the footpath will be designed as a ramp i.e. provides rest areas.</p>
Crossfall	<p>The maximum crossfall for any footpath is 2%.</p> <p>The crossfall of any footpath must facilitate stormwater flow to on-road drainage systems and not create ponding on the footpath or flow into private property.</p>
Vertical Drop	<p>In situations where there is more than a 1m high drop (i.e. safety from falling), within 1m of the back of a footpath, a handrail will be constructed. The handrail will be located at least 150mm away from the minimum footpath width (refer 4.13.3.3) and no closer than 150mm from the top of the bank. Refer SD420 to SD424.</p>
Overhead Clearance	<p>Footpaths will have a minimum vertical (overhead) clearance of 2.4m</p>

Note

It is acknowledged that in 'Hillside Environments' it may not be practical to achieve the footpath gradients or to design the footpath as a ramp. The gradient requirements are therefore not applicable to new roads in 'Hillside Environments' although careful specific design to the satisfaction of the Engineering Manager is required.

4.13.4 Crossings for Pedestrians and Cyclists

- 4.13.4.1 Having selected the appropriate crossing facility from the guidance in Table 4-17, the facility will be designed in accordance with the NZTA Pedestrian Planning and Design Guide.
- 4.13.4.2 All kerb crossing points must be designed to accommodate all potential users and to minimise the crossing distance for pedestrians. This means ensuring:
 - a) Kerb crossings are provided on both sides of the road;
 - b) Kerb crossings facilitate crossing perpendicular to the direction of the road;
 - c) The roadway is as narrow at the crossing point as possible;
 - d) Crossing facilities meet the same minimum design standards as footpaths with respect to crossfall, overhead clearance and surfacing.
- 4.13.4.3 At intersections, the kerb crossing will be offset from the intersection corner to line-up with the desire line. Where the ramp cannot be on the desire line, or where an intersection allows pedestrians traffic to cross the road at an angle, the kerb crossing ramp will be graded and carried around the quadrant of the kerb corner.

- 4.13.4.4 Kerb crossings will be located so that users have an unobstructed view of traffic approaching from any direction.
- 4.13.4.5 Tactile paving will be installed on all new and upgraded roads at all kerb crossings and other places where the footpath is not separated from the carriageway by an abrupt change in grade (more than 1 in 8) or vertical kerb face (higher than 70mm). Refer SD410.
- 4.13.4.6 Tactile paving will provide a high visual contrast to the adjoining walking surface. 'Safety Yellow' is the required colour standard for tactile paving.
- 4.13.4.7 The layout and installation of tactile paving will be in accordance with the NZTA Road and Traffic Guideline RTS 14 'Guidelines for facilities for blind and vision-impaired pedestrians.

4.13.5 Cycle Facilities

- 4.13.5.1 The design of cycle facilities will be in accordance with the NZTA Cycle Network Guidance and Austroads Guide to Road Design Part 6A – Paths for Walking and Cycling specify the facilities type that are to be provided by zone and hierarchy.
- 4.13.5.2 Where cycle facilities are provided mid-block, they will also be provided on the transition between mid-block and intersection, on the approach to the intersection, at the intersection (storage) and on the departure of the intersection.
- 4.13.5.3 Cycle facilities must be surfaced as per the minimum requirements of Section 4.22 Footpaths.
- 4.13.5.4 Where a cycle facility is provided within a road reserve that has frequent driveways, a buffer between the property boundary and the path must be provided to minimise the risk of a collision between a cyclist on the path and a vehicle exiting from a driveway.
- 4.13.5.5 A separation berm of 1.0m minimum must be provided between the path and carriageway where kerbside parking is permitted to avoid conflict between cyclists and opening doors on the left-hand side of vehicles.
- 4.13.5.6 A minimum lateral clearance of 0.5m (desirably 1.0m) must be provided between the edge of the path and any obstacle, including vegetation, light standards, signs, utility furniture, bollards etc.
- 4.13.5.7 Green coloured surfacing will be used at locations where motorists may be unaware of the likely presence of cyclists, or where motorists are likely to cross over the path of cyclists (for example at intersection transitions or across side streets or high volume private accessways). The green coloured surface will be G26 Apple Green or G31 Verdigris as specified in AS 2700S:1996. The supply and application of the green coloured surface will be in accordance with NZTA P33: 2017.
- 4.13.5.8 Cycle parking will be in accordance with AS 2890.3:2015 Bicycle Parking.

4.13.6 Public Accessways

- 4.13.6.1 The minimum legal reserve width of any public accessway will be 6m including berms and landscaping. Refer to SD427 for detailed design information.

- 4.13.6.2 Public accessways must be designed in accordance with the CPTED Guidelines so that a person using the public accessway can see from one end of the accessway to the other at all times.

Good Practice

The following standards can provide additional guidance on the design of the transport system for pedestrians, cyclists and public transport:

4.13.7 Public Transport

- 4.13.7.1 Residential development that does not have a frontage to a bus route will be provided with convenient walking access to that route.
- 4.13.7.2 Urban bus routes should be selected to take into account a highly accessible residential catchment that provides access to high transport intensity land uses (such as schools, tertiary institutions, hospitals, medical facilities, shopping areas, retirement villages and community facilities), typically using the 'Classified Roads' in residential neighbourhoods. These may extend onto Sub-Collector and Local Roads to maximise the residential catchment.
- 4.13.7.3 Residential development should be designed to maximise the number of sites within a five-minute walk (approximately 360m) of a bus stop.
- 4.13.7.4 An efficient urban bus service may be assisted by:
- Locating bus stops conveniently to maximise the walkable catchment while balancing spacing with bus journey times;
 - Locating bus stops on the downstream side of intersections;
 - Ensuring bus stops and the access routes to them have surveillance from surrounding development; and
 - Ensuring traffic management devices are bus friendly.

4.13.8 Footpaths

- 4.13.8.1 When considering the design of walking access, the NZTA 'Pedestrian Planning and Design Guide' and Table 4-18 should be taken into account.
- 4.13.8.2 Primary characteristic of walkable communities are summarised in Table 4-18 and these factors should be considered in the design of the transport network.

Table 4-18 Primary Characteristics of Walkable Communities

Characteristic	Description
Accessible	The places people want to reach, including bus stops, are within an appropriate walking distance.
Comfortable	The walking infrastructure is sufficiently wide, low gradient, smooth and clean. There is frequent shelter from the elements and places to rest.
Connected	The walking network connects people with places they wish to reach, including access to bus stops for longer trips.
Convenient	Walking routes are continuous, unimpeded by obstacles and minimise delay in preference for other road users.
Legible	The walking network is clearly signposted enabling visitors to find their way. Walking facilities are intuitive to use.
Pleasant	Walking spaces are enjoyable and interesting and encourage people to engage in social interaction.
Safe	Road and driveway access points are appropriately designed. The walking surface provides high levels of grip in the wet and is free of trip hazards.
Secure	The walking environment is designed using the principles of CPTED.
Universal	The walking network is suitable for pedestrians of all abilities including mobility and visually impaired persons.

4.13.8.3 The design of footpaths should satisfy a wide range of users and can be achieved by designing footpaths to accommodate the needs of children and disabled people.

4.13.8.4 Notwithstanding the widths specified in Table 4-6 and

4.13.8.5 Table 4-7 the minimum footpath width along any road with frontage to or within 200m to a;

- a) School;
- b) Aged care facility;
- c) Church;
- d) Sports field;
- e) Any high pedestrian generating activity;
- f) Should be widened to 2m minimum.

4.13.8.6 Crossing facilities should be a major consideration when developing pedestrian routes, as pedestrians' perceptions of the walking experience largely focus on difficulties crossing roads and any problems with this can cause delays and create a sense of insecurity.

4.13.8.7 Guidance as set out in Table 4-19 should be taken into account in the selection and design of crossing facilities.

Table 4-19 Crossing Facilities

Crossing Facility	Description	Example Treatments
Physical Aid	These facilities reduce crossing distances and simplify decisions.	Kerb extensions. Pedestrian islands. Raised medians.
Pedestrian Priority	These facilities provide pedestrians with intermittent (time separated) or continuous priority.	Zebra crossings. Kea crossings. Signalised mid-block crossings and intersections.
Spatially Separated	These facilities physically locate the crossing of pedestrians away from general traffic.	Underpasses. Overpasses.

4.13.8.8 Where topography or existing features preclude providing the minimum widths, discuss options with Council.

4.13.8.9 Footpaths may need to abut the kerbs in 'Hillside Environments', where the provision of additional road width to accommodate a berm would result in excessive earthworks.

4.13.8.10 In commercial areas the footpath surface type should extend across the berm area but be broken up by the inclusion of street furniture complementary to the commercial space such as cycle racks, litter bins, amenity planting and seating. Refer section 4.4.7.

4.13.8.11 In other areas, the location of the footpath should be selected by taking into account pedestrian amenity, sun and shade, road lighting, postal deliveries and likely use patterns.

4.13.9 Cycle Facilities

4.13.9.1 A safe, convenient and legible cycle network (cycleway) should be provided for both experienced and less experienced cyclists. The network may comprise both on-road and off-road routes.

4.13.9.2 Linkages for pedestrians and cyclists should create an attractive, friendly, connected, safe and accessible environment. These linkages should ensure that people can move about the community freely in areas where there are few vehicular road linkages.

4.13.9.3 The provision of a 'Shared Use Path' acknowledges that there is additional benefit to the community in allowing other users access to the path and also the impracticability of restricting users other than cyclists.

4.13.9.4 To minimise conflict between various users of a shared use path, the path should provide adequate sight distance between cyclists and other users.

4.13.9.5 A 'Shared Use Path' may be appropriate where:

- a) Demand exists for both a pedestrian path and a bicycle path but where the intensity of use is not expected to be sufficiently great to provide separate facilities;
- b) An existing low use footpath can be modified to provide for cyclists by satisfying legal requirements and as necessary upgrading the surface, width and kerb ramps; and/or
- c) There is an existing road nearby which is available for faster cyclists to use, to limit the extent of user conflict on the shared path.

4.13.9.6 The design of off-road cycleways should take into account the specific requirements of users of the route for example; commuter and/or recreational cycling, level of pedestrian activity etc.

4.13.9.7 Additional recommended guidance (to the NZTA Cycle Network Guidance web based document) on the cycle design of links and intersection can be found in the Austroads Guide to Road Design Part 6A and the [Christchurch City Council Design Guidelines - Design Principles Best Practice Guide](#)

4.13.9.8 Cycle facilities are generally not required on 'Unclassified Roads' because these roads typically have low traffic volumes and are designed to achieve operating speeds that facilitate safe cycling in a mixed traffic environment.

4.13.9.9 The following guidance informs the provision of cycle facilities on lower order roads:

- a) Roads that have a speed environment of 40km/hr or lower and carry less than 5,000 vehicles per day (vpd) do not require specific provision for cyclists;
- b) Roads that have a speed environment of 40-50km/hr and carry more than 2,500 vehicles per day should be designed to accommodate cyclists separately from the traffic lane;
- c) Roads that have a speed environment of 50-60km/hr or more should be designed to accommodate cyclists separately from the traffic lane.

4.13.9.10 Cycle facilities located against the kerb also create issues on rubbish/recycle collection days, as collection is usually placed kerbside. The inclusion of a separating berm allows for this activity to not encroach into the cycle facility space.

4.13.10 Crime Prevention through Environmental Design (CPTED)

4.13.10.1 Ensure pedestrians and cyclists are able to see and be seen clearly in the surrounding area. Avoid sudden corners, blind bends and recessed or entrapment areas along walking/cycling links and ensure that planting does not grow to reduce passive surveillance or provide hiding places for offenders.

4.13.10.2 Choose lighting that illuminates pedestrian and cycling areas as well as roads and ensure it is consistently placed to not conflict with planting or create large areas of shadow. Refer Chapter 9 Telecommunications, Electrical and Street Lighting for details.

4.13.10.3 Provide environments that encourage a high level of social interaction, by designing walking/cycling links that are well patronised.

4.13.11 Intersections and Connectivity

4.13.11.1 Non-vehicle accessways should ensure an attractive and well-connected network that can encourage more people to cycle to local destinations, thus improving their health and reducing reliance on the private motor vehicle as a form of transport.

4.13.11.2 Appropriate intersection treatments can ensure route continuity.

4.14 Road Marking and Signs

This section deals with communication on and around roads, including road marking and signage.

Mandatory Requirements

These standards are required for all road marking and signage:

4.14.1 Road Marking

4.14.1.1 In the Nelson City Council area, the following standards apply:

- a) Centrelines are marked on all 'Classified Roads' and 'Unclassified Roads' that have a speed limit of 60km/hr or above;
- b) Centrelines are marked on sections of roads where insufficient forward visibility is provided between opposing vehicles on narrow carriageways to see each other and stop (refer Table 4-9 for Safe Stopping Sight Distances for various design speeds).
- c) Edge lines are marked on all 'Classified Roads' and on the outside of bends on 'Unclassified Roads' in rural areas.
- d) Edge lines may also be provided on other roads to improve delineation.
- e) No stopping lines are marked within the turning head of a cul-de-sac. However, the use of no stopping lines in other locations must be approved by the Engineering Manager.

4.14.1.2 Tasman District Council requires that all roads are signed and marked in accordance with the Council's Delineation Policy.

4.14.1.3 All new and upgraded roads will provide traffic signs in accordance with The Manual of Traffic Signs and Markings (MOTSAM) and the Traffic Control Devices Rule.

4.14.1.4 All new and upgraded roads will provide road marking in accordance with the NZTA Manual of Traffic Signs and Markings (MOTSAM) – Part II Markings and the Traffic Control Devices Rule.

4.14.1.5 All new edge-lines, centrelines, continuity lines and limit-lines will be reflectorised with Type C glass beads to AS/NZS 2009: 'Glass beads for pavement-marking materials' applied at 275g/m² and 330µm dry film thickness. A second coat is required after six to eight months. A water-based paint may be used for the second coat.

4.14.2 Signs and Gateway Treatments

4.14.2.1 Developers constructing new roads will submit to the Council, at the time of submission of Engineering Plans, a list of suggested road names, with alternatives, including any supporting information for the preferred choices. This includes private ways, walkways and public

accessways. The Designer will be advised of the name(s) that have been approved by the Council in terms of its policy.

- 4.14.2.2 Council will not allow the same names as others used in Tasman or Nelson.
- 4.14.2.3 All walkways and public accessways will use the word 'Way' on the sign.
- 4.14.2.4 Gateway structures and signs are not permitted on Road Reserve. Gateway signs may be located on private land provided they do not restrict visibility and comply with the relevant Resource Management Plan requirements for signs. Maintenance of gateway signs and structures will be a private responsibility.
- 4.14.2.5 All signs must be shown on the Engineering Plans for approval by the Engineering Manager prior to construction.

Good Practice

The following matters can provide additional direction and guidance in relation to road signs and markings:

4.14.3 Road naming

- 4.14.3.1 In Tasman, guidance is provided in the Tasman District Council "Street Naming Policy". Guidance is also provided by AS/NZS 4819.
- 4.14.3.2 Road name frames and posts may be customised to suit the character of the subdivision and matched with street lighting columns and other street furniture, subject to approval by Council.
- 4.14.3.3 Gateway signs and structures need to be carefully considered and designed to ensure they are not interpreted by the public as private areas, where no through access is provided or permitted.
- 4.14.3.4 Consideration must be given to local Maori names for roads that reflect local landmarks, cultural affiliations, historical use or events.

4.15 Streetscaping

This section deals with things like paving, berms, street trees, plant beds, streetlights and street furniture which improve amenity and functionality for a range of users.

Mandatory Requirements

The following requirements relate to streetscaping design and installation:

4.15.1 General

- 4.15.1.1 Grassing, planting including street trees must be installed at least three to six months (depends on the time of year and grass sward and plant establishment) prior to the application for section 224(c) certificate.

4.15.1.2 Replace any trees that die or are damaged during the next growing season within the maintenance/defects period.

4.15.1.3 Watering during the first two summers if required to maintain planting and tree health.

4.15.2 Grassing

4.15.2.1 Berms and the service strip will be a grassed surface or planted in accordance with Section 4.5.3. Topsoil to a firm minimum thickness of 100mm on clay surfaces and 150mm on sandy or gravelly surfaces will then be spread so that a smoothly contoured surface is produced, free of ponding areas. The subgrade will be capable of allowing root penetration and sustaining growth.

4.15.2.2 The final topsoil surface will be flush with the adjacent kerb and footpath and sown with approved grass seed mixtures.

4.15.2.3 The slope of the grass berms from kerb to boundary will generally be 1-in-33 (3%). This slope may vary, but will not be less than 1-in-50 (2%) nor more than 1-in-12 (8%).

4.15.2.4 After topsoiling, the berms will be sown with grass seed that conforms to the following mix proportions:

- a) 1.0kg chewings fescue;
- b) 4.5kg dwarf rye grass;
- c) 0.5kg browntop.

4.15.2.5 The mixture will be sown at a rate of 1kg to 40 square metres area.

4.15.2.6 Prior to the sowing of the grass seed, fertiliser will be spread and mixed with the topsoil. The recommended fertiliser is superphosphate applied at a rate of 30g per square metre.

4.15.2.7 After two months dressing with superphosphate, a dressing with Sulphate of Ammonia applied at a rate of 30g per square metre will be applied.

4.15.3 Planting

4.15.3.1 Planting plans will be provided to the Engineering Manager for checking and approving at the same time as the design engineering plans. Planting of berms and service strips is encouraged where it can meet the requirements in Section 4.15.3.2 below, and is for the purpose of achieving a high amenity low speed environment, enhancing amenity and streetscape in higher density developments and/or accommodating low impact stormwater devices.

4.15.3.2 Plantings will be designed to meet the following requirements:

- a) Street gardens must be located so as not to compromise the integrity and efficient operation of infrastructural services or cause obstruction to transport users;
- b) The number of species used should be minimised and ensure a unified result and species choice in street gardens;
- c) Street gardens should support trees of a reasonable scale to reach 100 years old;
- d) Suitability to environmental conditions for example; ground moisture, wind, etc.;

- e) Pest and disease resistance;
- f) Minimum maintenance requirements.

4.15.4 Street Trees

4.15.4.1 Street tree planting is required and should contribute to the outcomes required in section 4.1.

4.15.4.2 The selection of street tree species will be:

- a) In Nelson from the list on the following link:
<http://nelson.govt.nz/assets/Environment/Downloads/land-development-manual-2010/731314-Street-Tree-Guidelines-19Feb2009.pdf>
- b) In Tasman from the list on the following link:
https://www.tasman.govt.nz/home/SearchForm/?Search=street+tree&action_results=Search

4.15.4.1 All trees will be healthy vigorous and free of any defects that may be detrimental to plant growth and development. Council requires the use of locally sourced native species where appropriate.

4.15.4.2 Street tree plantings will be designed to meet the following requirements:

- a) The mature size of any tree or garden planting will be assessed for each planting location and is to be in scale with the surrounding street environment and the space available and be shown on the planting plan;
- b) Street trees and landscaping species must be selected and located so that growth to maturity or 100 years whichever is the lesser will not impede pedestrian flow, compromise the integrity and efficient operation of infrastructure services, or reduce visibility on curves or at driveways;
- c) Street trees will be provided on service free berms that are at least 1.5m in all directions (or larger as required by Section 4.15.3) or services free paved areas within commercial areas as appropriate;
- d) The positioning of street trees within the road must not create a hazard to vehicles that leave the road. Non-frangible trees, (trees with a trunk of more 100mm diameter measured 400mm above ground surface at maturity) will be positioned so that the clear zones specified in Section 4.11 and the sight lines in Table 4-12 are satisfied;
- e) The minimum planting size of a landscape tree is 1.8m tall at the time of planting and 50mm stem diameter at chest height to minimise vandalism;
- f) No trees or shrubs will be planted within a 2.0m radius of any water valve or hydrant;
- g) The planting hole for the tree will be excavated at least 1m deep and 1.5m square. Good quality soil/compost should be added and the walls of the hole to be loosened to assist root development;
- h) Root barriers will be used within berms along the road kerb edge and footpath edge where appropriate to reduce the likelihood of footpath/road damage. These will extend for an appropriate distance each side of the tree. The distance will depend on the species of tree shown in the approved plan required by 4.15.4.1 above. See SD430;
- i) Tree pit “root directors” and ‘root cells’ are required where trees are within asphalted or hard surfaces. The subgrade below the tree pit must allow roots to grow into the ground surface. It is to be free draining and will not contain any rocks or concrete materials;
- j) Wooden tree staking will be undertaken in accordance with SD430.

4.15.5 Street Furniture

- 4.15.5.1 Street furniture will be standard readily available products intended for the commercial/public space environments, not bespoke or custom designs unless approved by the Engineering Manager. This is to minimise the long-term maintenance cost and make replacement easy in the event of damage.
- 4.15.5.2 Every piece and type of street furniture will be easily detectable (and avoidable) by the vision impaired. This means each street furniture element must:
- Have an element within 150mm of the ground for its entire length parallel to the ground, so that it is detectable by a vision impaired person with a cane;
 - Be placed so that the minimum 'Through Route' widths are maintained. See Section 14.2 of the NZTA Pedestrian Planning and Design Guide;
 - Be placed in a consistent manner to promote the confident movement of vision impaired persons;
 - All street furniture that is located within the clear zone will be collapsible or frangible so as not to create a hazard for vehicles that leave the road.

Good Practice

4.15.6 General

- 4.15.6.1 Opportunities for street trees and landscaping will be taken where possible to improve the visual amenity, recreational quality, biodiversity and ecological links. Clustered planting and a small number of specimen trees in widened berm areas is encouraged over a consistent linear layout.

4.15.7 Planting and Grassing

- 4.15.7.1 Landscaping should be designed to meet the following objectives:
- Provide a sense of separation between the road and the footpath;
 - Integrate with the network of reserves and open space and compliment street tree planting;
 - Maintain adequate visibility for road users;
 - Maintain adequate visibility from residential properties to the road;
 - Provide separation from parking areas;
 - Frame views by emphasising landscape features;
 - Soften hard surfaces;
 - Enhance aesthetic values.
- 4.15.7.2 Berms and service strips should be designed to take into account space for pedestrians to pass, access to and from parked vehicles, a corridor for underground utilities such as water, power and telecommunications, and the planting of street trees and plant beds.

4.15.7.3 Where a material or plantings other than grass is used between the footpath and the property boundary, the treatment should be discussed with Council to ensure the sight line visibility, on-going maintenance and safety issues are addressed.

4.15.7.4 Alternative fertiliser and application rates to suit local conditions may be used subject to prior consultation with the Council.

4.15.7.5 Plant species should be local native plant species, subject to being appropriate to use and conditions of the site.

4.15.8 Street Trees

4.15.8.1 Street trees should enhance and strengthen the existing and intended future character of neighbourhood areas. Tree planting will provide maximum long-term benefit to the public with minimum ongoing maintenance. It must not compromise the safe use of the legal road reserve or affect its structural integrity.

4.15.8.2 Street trees should be established in areas where there the service free berm area can be combined with a buildout for carriageway narrowing, inset parking or similar to give the maximum amount of landscaped area for the tree to thrive and mature.

4.15.8.3 Street trees are preferred on the north side of the street to minimise property shading in winter months, with smaller mature height trees planted on the south side for balance.

4.15.8.4 Trees should not be planted within the rear (services) berm or in road verges less than 1.5 metres in width.

4.15.8.5 Plant species should be local native plant species, subject to being appropriate to use and conditions of the site.

4.15.9 Street Furniture

4.15.9.1 Street furniture design should be sympathetic to the surrounding environment and, where it is intended for use by pedestrians, should be accessible to all users.

4.15.9.2 Seats should be provided near intersection nodes on the footpath and public accessway network to allow rest spots for our aging population and to providing space and opportunity for people to meet and interact.

4.15.9.3 Typical characteristics and conventional locations of common street furniture for new or upgraded streets roads are shown in Table 14.9 of the NZTA Pedestrian Planning and Design Guide.

4.16 Construction General

This section outlines Council's expectations for construction.

Mandatory Matters

4.16.1 General

- 4.16.1.1 The Designer will nominate the method of construction for approval by the Council.
- 4.16.1.2 If the Designer wishes to use a method of construction other than the standard New Zealand Transport Agency specifications then full details of the construction method including programming, plant, etc. will be submitted to the Council for approval.
- 4.16.1.3 The Designer will also submit details of where the nominated alternative construction method has previously been employed together with performance details, acceptance testing results and an independent reference in support of this method.
- 4.16.1.4 If no specific alternative construction method is nominated and approved by the Council, then all works will comply with the New Zealand Transport Agency Specifications.

4.16.2 Road Assessment Maintenance Management (RAMM) Data

- 4.16.2.1 The Designer will submit a completed Road Assessment Maintenance Management (RAMM) Data Sheet (see Appendix A) to the Council for each separate job or section of a continuing job which involves road construction. This will be submitted at the as-built engineering plan stage.

4.16.3 Earthworks

- 4.16.3.1 Land disturbance and earthworks activities are the subject of rules within the NRMP and TRMP. All relevant resource consents and implementation of an approved Erosion and Sediment Control Plan (if needed) will be required before any earthworks or land disturbance can begin.
- 4.16.3.2 NZS 4431: Code of Practice for Earthfill for Residential Development will, except as noted below, provide the standard for fill placement generally.
- 4.16.3.3 In areas of unenclosed filling, where the original ground has a slope steeper than 1-in-2.75 (36%), the original ground surface will be properly prepared before any material is placed against it.
- 4.16.3.4 Any benches will be of sufficient width to accommodate compaction and spreading equipment and will be arranged so as to be adequately drained during the placement of filling material.
- 4.16.3.5 The depth of the layer will be related to the type and model of compaction plant proposed to be used and the type and size of material.
- 4.16.3.6 The Designer will nominate the proposed layer depths and plant and should expect to be required to supply supporting documentation that shows that the proposed compaction method is compatible with the material being used.
- 4.16.3.7 When no information is supplied the following will apply:
 - a) In the carriageway within 500mm of the finished subgrade, the layers will be spread and compacted to a loose depth not exceeding 150mm;

b) Elsewhere, the layers will be spread and compacted to a loose depth not exceeding 200mm.

- 4.16.3.8 The material will at all times be placed at a moisture content close to the optimum moisture content for the material under consideration. The allowable tolerance will not exceed limits of minus 2% or plus 2%. The Designer will be responsible for supplying a test certificate, quoting optimum moisture contents of the materials encountered on the work.
- 4.16.3.9 The Designer will ensure that for heavy clay silts, sandy clays and gravels the minimum density to be achieved is 95% of the maximum dry density, and for sands the minimum density to be achieved is 100% of the maximum dry density.
- 4.16.3.10 The maximum dry density will be obtained by standard compaction at optimum moisture content as detailed in NZS 4402: Methods of Testing Soils for Civil Engineering Purposes.
- 4.16.3.11 Within the carriageway the criteria for the structural design of pavement (Section 4.17 'Structural Design of Pavement') will take precedence over standards of compaction given in this clause.
- 4.16.3.12 All earthworks and land disturbance activity will cease immediately upon the discovery of cultural heritage artefacts, in accordance with the Heritage New Zealand Pouhere Taonga Act 2014.
- 4.16.3.13 Where there is a known high risk of accidental discovery, a cultural heritage monitor must be present during all excavation works.

4.16.4 Earthworks Routine Testing

- 4.16.4.1 Routine testing will be carried out on earthworks at the rate of one test every one metre depth of filling spaced at 30 metre grid points over the area concerned.
- 4.16.4.2 The results of these tests will be supplied to the Council. All tests prior to and during construction will be carried out by or under the supervision of a Designer experienced in soil compaction techniques. The Council may carry out further tests at any stage if it considers them necessary.
- 4.16.4.3 Where mass earthworks (cutting or filling) are proposed that will extend beyond existing or proposed road boundaries the Council will require the following information, in addition to any requirements under Section 4.16.3:
- A plan showing the contours or levels of the existing site, final contour levels, the existing watercourses, together with any available information on the water table and the ground surface of the area concerned, and logs of any bores taken during investigations;
 - The positions of boreholes and other geotechnical investigation/testing are to be geo-referenced;
 - A pattern of sections showing the extent of cut and fill and a plan showing batter slopes, drainage or culverting;
 - The naming of a Designer experienced in soil compaction techniques who will be responsible for supervising and controlling the operations on the site as set out in the specification;
 - A specification on the compaction methods and degrees of compaction required, also giving moisture/density test results of the soil to be encountered;

- f) On completion of the earthworks certification from a suitably experienced Geo-Professional will be supplied from the Designer, stating that the requirements of the specification have been carried out and giving details of the test results in accordance with the requirements of the specification (as per Section 10 of NZS 4431 Code of Practice for Earthfill for Residential Development).

Good Practice

The following matters provide additional guidance and direction in respect of Council's expectations for land preparation for road construction.

4.16.5 Land Stability

Where the area of earth fill does not exceed 100m² and the depth does not exceed 600mm maximum, the requirement concerning testing (Section 4.16.4 'Routine Testing') may, at the discretion of the Engineering Manager, not be enforced.

4.16.6 Sedimentation and Erosion Control

All earthworks and land disturbance should be guided by the Sedimentation and Erosion Control Guideline current at the time of development.

4.17 Structural Design of Pavement

This section sets out Council's expectations for the structural design of pavements.

Mandatory Matters

The following matters are required aspects of the structural design of pavements:

4.17.1 General

- 4.17.1.1 Generally, pavement will be flexible designs. Other types will be subject to Engineering Manager Approval.
- 4.17.1.2 The pavement design will use the guidance in Austroads Guide to Pavement Technology Part 2: Structural Design (2017).
- 4.17.1.3 The pavement of all Classified roads and Unclassified roads within Industrial zones will be:
- Designed using a mechanistic design method;
 - Use soaked California Bearing Ratio values in the laboratory of the pavement subgrade in accordance with 6.1 of NZS 4402.6;
 - Use equivalent standard axle (ESA's) loadings derived from actual and forecast traffic volumes over a 25-year life or 6×10^6 ESA whichever is the greater;
 - For flexible pavements the minimum layer of M4 AP40 basecourse will be 150mm.
- 4.17.1.4 The pavement of all Non-Classified roads and private accessways excluding Industrial roads will be:
- Designed using a mechanistic design method or empirical chart-based method;

- b) Use soaked California Bearing Ratio values in the laboratory of the pavement subgrade in accordance with 6.1 of NZS 4402.6 or when recommended by a soils specialist the determination of the CBR may be by scalar penetrometer in accordance with clause 3.3.3.2 and figure 3.1 of NZS 4404;

4.17.1.5 Use equivalent standard axle (ESA's) loadings derived from actual and forecast traffic volumes over a 25-year life or the default ESA values in Table 4-20 for each non-classified hierarchy whichever is the greater;

- a) CBR Method - CBR design curves are given on SD402 or Austroad's 'Guide to Pavement Technology Part 2: Pavement Structural Design (2017)' the Structural Design of Road Pavements' Figure 8.4;
- b) For flexible road pavements and private ways in commercial and industrial zones the minimum layer of M4 AP40 basecourse will be 200mm but may be reduced to 150mm minimum if a granular sub basecourse layer is used;
- c) For flexible residential and rural private accessway pavements the minimum layer of M4 AP40 basecourse will be 150mm but may be reduced to 100mm minimum if a granular sub basecourse layer is used.

Table 4-20 Design Traffic Loading ESA Minimums

Hierarchy	Zone	Design Traffic Loading in ESA
All Classified	All	6 x 10 ⁶
Sub Collector Residential and Commercial	Residential & Rural Lifestyle	2 x 10 ⁶
	Commercial & Rural	3 x 10 ⁶
	Industrial	4 x 10 ⁶
Access Road	Residential & Rural Lifestyle	9 x 10 ⁵
	Commercial & Rural	1 x 10 ⁶
	Industrial	2 x 10 ⁶
Access Lane	Residential	4 x 10 ⁵

4.17.2 Submission of Test and Design Data

4.17.2.1 The following information will be submitted at the same time that Engineering Drawings are submitted for approval:

- a) All test information obtained to inform the pavement design;
- b) The traffic loading and design calculations including model outputs were appropriate used to determine pavement design.

4.17.3 Basecourse and Sub-basecourse Aggregate

4.17.3.1 Basecourse aggregate used in the construction of pavements will comply with NZTA M4 specification.

4.17.3.2 Sub-basecourse aggregate used in the construction of pavements will comply with SD401.

4.17.4 Acceptance Criteria – Pavement Strength

- 4.17.4.1 For classified roads testing to confirm compaction will be carried out in accordance with TNZ B/02.
- 4.17.4.2 For unclassified roads the Designer will nominate either testing in accordance with TNZ B/02 or Benkleman Beam Testing.
- 4.17.4.3 Testing will be carried out immediately prior to the surfacing of the pavement.
- 4.17.4.4 For Benkleman Beam tests the maximum allowable deflections will comply with Table 4-21.

Table 4-21 Maximum Pavement Deflection

Road Hierarchy	Maximum Deflection (mm)
Arterial Roads	0.8
Principal Roads	1.0
Collector/Sub-Collector/Industrial/Commercial Roads	1.3
Local Road/ Residential Road or Industrial/Commercial Private Way	1.5
Residential Lanes	1.8
Residential Private Ways	2.0

Notes

- 1) One test will be undertaken in every wheel track at 20m intervals but staggered to give tests at 10m spacing in each traffic lane.
- 2) Not more than 5% of the tests will exceed the maximum.
- 3) No single result will exceed the maximum allowable by more than 50%.
- 4) Any area of excessive deflection will not exceed 5.0 square metres.

- 4.17.4.5 Where any areas of the carriageway fail the acceptance testing the Designer will nominate the proposed remedial action for approval by the Council.
- 4.17.4.6 If required by the Council the failed areas will be dug out and clean sub-base and or basecourse compacted in the excavation, and the surface prepared for sealing.
- 4.17.4.7 A further set of tests will be carried out to show that the affected area is up to the required standard.

4.17.5 Acceptance Criteria – Road Profile

- 4.17.5.1 The finished shape of the road will be such that when a straight edge is laid parallel to the centre line of the road or a camber board laid perpendicular to the centre line, the surface will not vary from the straight edge or camber board by more than 10mm in any 3-metre length.

- 4.17.5.2 Prior to sealing, the surface of the road will be clean, reasonably dry, and free of ice, frost, or loose material, tightly compacted and will present a clean mosaic appearance.
- 4.17.5.3 All concrete surfaces, channels, sump surrounds, service boxes, manholes etc will be completed to their final height to fit the finished (sealed) road profile prior to sealing.
- 4.17.5.4 All service boxes and manhole lids will be finished to within 5 to 10mm above the finished (sealed) road profile.

4.17.6 Stabilisation of Construction Courses

- 4.17.6.1 Where the Designer chooses to use stabilising agents on the construction courses to reduce the depths required, they will supply supporting information and test results to demonstrate the type and quantity of stabilising agent is compatible with the type of material and projected traffic loadings.
- 4.17.6.2 The Designer will indicate relevant experience in this field and also supply information on the experience of the proposed contractor.
- 4.17.6.3 This design option will only be permitted after consultation with and approval by the Engineering Manager.
- 4.17.6.4 Where a layer of filter fabric/geotextile is required, due to the ground conditions, to separate the subgrade from construction courses, the design of the filter fabric/geotextile layer will comply with the Notes to the TNZ specification F/7 Geotextiles and the supply and placing will conform to the TNZ specification F/7 Geotextiles.
- 4.17.6.5 The use of geotextiles as a structural element of the pavement design will only be permitted after consultation with and approval by Council.

Good Practice

The following matter provides additional direction and guidance regarding the structural design of the pavement:

4.17.7 General

Alternative design for pavement structure may be allowed to specific limited areas and with the approval of Council.

4.18 Subgrade

This section sets out Council's expectations and standards for the design of and construction of the subgrade.

Mandatory Matters

The following matters are required in the construction of road subgrades:

4.18.1 Subgrade testing

4.18.1.1 Subgrades are inherently variable in nature and reflect the changes in topography, soil type, and drainage conditions that generally occur along an existing or proposed road alignment. The selection of a subgrade design value requires adequate consideration of the degree of variability within a particular project section and the quantity and quality of data on subgrade properties. Subgrade test sites will be:

- a) Spaced at no greater than 120 m for non-rural project/development;
- b) Spaced at no greater than 300 m for rural project/development;
- c) No less than three test sites in any project/development;
- d) Where there is a variation along a project, at least three test sites should be considered for each subgrade, topography and drainage combination.

4.18.2 Subgrade Drainage

4.18.2.1 Subgrade and subsoil drainage will be designed and installed in accordance with TNZ F/2 and F/7 specifications and the accompanying notes.

4.18.2.2 When the road or private accessway is in-cut, a sub-soil drain will be placed below the toe of the batter and connected into the back of the nearest sump downstream.

4.18.2.3 Any permanent wet spot in the subgrade or any area undercut below adjacent sub-soil drains will be connected to the nearest piped stormwater system by another sub-soil drain. Where the drain is located under the carriageway, traffic loading will be taken into consideration for the type of pipe.

4.18.2.4 In areas of high groundwater or where the road pavement design is reliant on the subgrade remaining dry, it may be necessary to install a sub-soil drainage system piped to the nearest stormwater system to prevent excessive moisture getting into to the subgrade.

Good Practice

These matters provide additional guidance and direction in regard to the road subgrade:

4.18.3 Subgrade testing

4.18.3.1 Where the extent of cut or fill for the project is too great to make subgrade testing feasible at the design stage, it may be done on completion of earthworks when subgrade levels have been exposed.

4.18.3.2 Council may require that where subgrade has been tested as part of the design, its condition be reviewed on exposure during construction and pavement thicknesses adjusted accordingly.

4.18.3.3 Council may require the results of such testing and/or review along with consequent adjustments to pavement layer thicknesses before placing of pavement layers commences.

4.19 Carriageway Surfacing

This section outlines Council's expectations for carriageway surfacing.

Mandatory Matters

The following standards are required conditions for carriageway surfacing:

4.19.1 General

- 4.19.1.1 Surfacing will be in accordance with NZTA P/3 for first coat chip seals, NZTA P/17 for reseals and NZTA M/10 for dense graded asphalts.
- 4.19.1.2 Two coat chip seals are the minimum requirement for:
- Urban and rural carriageways in Residential and Rural Lifestyle zones carrying under 10,000vpd or forecast to carry less than 10,000vpd within the next eight years;
 - Private ways in residential zones serving more than one unit.
- 4.19.1.3 In urban areas the wearing surface will be a two coat Grade 4 and Grade 6 chip seal. In rural areas a wearing surface of two coat Grade 3 and Grade 5 chip seal will be applied.
- 4.19.1.4 Asphaltic Concrete (50mm of DG10 or Mix 15D at the Engineering Managers approval) is the minimum requirement for:
- Urban Carriageways in Commercial and Industrial zones;
 - All high stress locations such as roundabouts, intersections and cul-de-sac turning heads etc;
 - All urban streets in residential zones carrying 10,000vpd or forecast to carry within eight years more than 10,000vpd;
 - The road carriageway where a commercial or industrial activity entrance enters/exits on to the existing or new road for the full width of the carriageway and 10m either side of it.
- 4.19.1.5 Prior to surfacing, the basecourse finish will be such that when swept it presents a tightly consolidated mosaic surface in which the large aggregate is exposed to the surface and is held in place with a matrix of smaller aggregates and the smaller aggregate is held in place by fine material and the matrix does not displace under normal trafficking or sweeping.
- 4.19.1.6 The standard of sweeping will be sufficient to remove all loose aggregate, dirt, dust, silt and other excess chip seal.
- 4.19.1.7 Prior to sealing water content testing of the basecourse layer will be carried out in accordance with section 12 of NZTA B/02.

4.19.2 Seal Design

- 4.19.2.1 The Designer will submit the seal design, for approval by the Council a minimum of seven days prior to any sealing commencing.
- 4.19.2.2 The submitted designs will include details of:
- Sealing binder to be used;
 - Additives to be used;

- c) Application rates;
- d) Hot spray temperature/range;
- e) Sealing chip test results;
- f) Construction method/plan.

4.19.3 Sealing Binder

4.19.3.1 The materials used will meet the requirements of the relevant clauses of the following NZTA specifications.

- a) TNZ M/1: Roading Bitumens;
- b) M/13: Adhesion Agents.

4.19.3.2 Sealing base binder will be 130/150 penetration grade bitumen or as agreed with the Designer.

4.19.4 Sealing Chip

4.19.4.1 Sealing chip will meet the requirements of NZTA M/6 Specification for Sealing Chip.

4.19.5 Ground Sterilising

4.19.5.1 Immediately prior to any form of surfacing, a strip one metre wide adjacent to each channel will be applied with an approved ground sterilising weed killer at the manufacturer's recommended rate of application.

4.19.6 Application of Sealing Binder

4.19.6.1 All sprayers will meet the requirements of BCA E/2 and have a current E/2 certificate.

4.19.6.2 Spraying operations will be carried out so that private property and street furniture are not affected by overspray.

4.19.6.3 The end of each sealed area will be a straight line at right angles to the road edge. Sealing runs should start and finish on paper and no binder will be allowed to drip onto sections of the roadway that have previously been sealed.

4.19.6.4 An overlap of 50mm will be applied to concrete kerbs, channels and edge restraints.

4.19.7 Application of Chip

4.19.7.1 Chip spreading equipment will be capable of spreading the aggregate evenly, at a controlled rate and in such a way that chip does not tumble on impact with the sprayed surface.

4.19.7.2 All excess chip will be swept from the carriageway and removed from the channels, footpaths, berms and sumps prior to the acceptance of the works by the Council.

4.19.8 Acceptance Criteria

4.19.8.1 The two-coat seal will provide a fully interlocked surface after rolling. Chip loss, bleeding or flushing will not exceed 5% in any one metre by one metre square of the total sealed area during the maintenance period.

4.19.8.2 The developer will ensure that all reseal repairs are carried out to a standard that will not contribute to flushing in the new seal. Any areas of flushing caused by the sealing operations will have all excess bitumen removed so that all acceptance criteria are achieved including any adjacent affected areas.

4.19.9 Dense Graded Asphalt (Asphaltic Concrete)

4.19.9.1 Asphaltic Concrete will be designed and constructed in accordance with NZTA M/10 'Specification for Dense Graded and Stone mastic Asphalts'.

4.19.9.2 For non-classified residential streets dense graded asphalt will comply with NZTA Specification M/10 Table 3.2 'DG7' and will be a minimum compacted thickness of 25mm. The binder will be 80/100-penetration bitumen or as agreed with the Designer.

4.19.9.3 For classified streets and all commercial and industrial zones, dense graded asphalt will comply with NZTA Specification M/10 Table 3.1 DG AC10 and will be a minimum compacted thickness of 50mm. The binder will be 80/100-penetration bitumen or as agreed with the Designer.

4.19.9.4 The dense graded asphalt wearing course will be laid on a Grade 5 membrane chip seal with a tack coat applied to all exposed edges, including any vertical faces on service boxes. If bitumen (not emulsion) is used it will be straight run.

4.19.9.5 All cold asphalt joints are to be Polymer Modified Bitumen (PMB) hot bandaged.

4.19.9.6 The bandage will be at least 100mm wide and 1.5mm thick. Alternative PMB methods will be considered by Council.

Good Practice

These matters provide additional guidance and direction in regard to the carriageway surface:

4.19.10 General

4.19.10.1 Emulsions are encouraged as they keep people safe throughout every stage of handling the product, offer environmental benefits and can be applied in cooler temperatures thus extending the sealing season.

4.19.10.2 Alternative surfacing may be allowed to specific limited areas with the approval of the Council.

4.19.10.3 The seal design and construction plan required in section 4.19.2.2 should be developed based on the guidelines below:

- a) The carriageway will be measured and divided into workable sections to create a 'paving plan'. The size of these sections will be limited to the area of seal that can be completed using the volume of binder on site. (To be complete both coats of two coat seals will be applied) for chip seal and for dense graded asphalt to ensure the paver can operate continuously at constant speeds suited to the rate of supply from a single supply source operated to minimise cold joints;
- b) Individual spray run areas are not to exceed the area that can be chipped at the correct chip spread rate within 5 minutes of being sprayed;

- c) The total rolling requirement is related to the amount of binder sprayed. Contractors are to calculate and document within their construction plan the number of passes required for each section of seal completed;
- d) Where longitudinal joints occur they will be marked out straight and true and be parallel to the centreline. A strip of the first sprayed area will be left unchipped to allow effective jointing with the next pass of the sprayer and the next spray run will overlap to the extent recommended in the Certificate of Compliance for the distributor. No traffic will be allowed to cross uncovered binder;
- e) No longitudinal joints are to be positioned within carriageway vehicle wheel paths;
- f) Where new dense graded asphalt paving abuts an existing surface, that surface should be cut back to form a vertical face for the full depth of the new paving;
- g) Multi and two coat seal longitudinal joints will be positioned to ensure overlaps do not occur in the same location;
- h) Spraying will start and stop within the paper strips;
- i) All binder will be sprayed within the correct temperature range. (see seal design).

4.20 Formation of Residential Lanes, Service Lanes and Private Ways

This section sets out Council's expectations for the formation of residential lanes. Service lanes and private ways.

Mandatory Matters

The following matters are requirements for the formation of residential lanes, service lanes and private ways:

4.20.1 General

- 4.20.1.1 The finished surface will have a crossfall of 1-in-33 (3%) and shaped with a crown or mono crossfall.
- 4.20.1.2 All topsoil and growth will be removed and compacted basecourse and sub basecourse (where required) laid and graded to an even surface.
- 4.20.1.3 The pavement will be designed as detailed in Section 4.17 'Structural Design of Pavement'.
- 4.20.1.4 All formations are to be surfaced in accordance with Section 4.19 'Carriageway Surfacing'.
- 4.20.1.5 Kerb and channelling on private ways on at least one side for the full length of the private way with the crossfall towards it will be required when any of the following are present:
 - a) The private way has a gradient of less than 1-in-60 (1.7%);
 - b) The private way has a length in excess of 20m;
 - c) Three or more potential household units served by the access.
- 4.20.1.6 For residential lanes, kerb and channel will be provided on the footpath side for the full length and the crossfall will fall towards this. A nib kerb, or similar, will be provided on the other side for the full length of the residential lane.

- 4.20.1.7 At intersections of residential lanes, service lanes and private ways with higher order roads a standard access crossing will be constructed (SD406) so that the footpath and kerb runs through. This is to signal to drivers they are entering slow shared space and give pedestrians right of way on the higher order alignment.
- 4.20.1.8 For service lanes, kerb and channel will be provided on both sides for the full length.
- 4.20.1.9 The high side of the formation will be retained by either of the following: kerb and channel, nib kerb
- 4.20.1.10 The kerb and channel will be constructed in accordance with Section 4.21 'Kerb and Channelling'.
- 4.20.1.11 For private ways more than 10m in length or more than 30m² of sealed surface, all stormwater off the formation will be collected and discharged to an approved stormwater system.
- 4.20.1.12 Sumps will be located at the low side of the formation within kerb and channel (or similar) and at the street boundary where falls are towards the carriageway. New sumps will not be permitted within a vehicle access point on the line of the street kerb and channel (or edge of seal where there is no kerb and channel).

Good Practice

These matters provide additional guidance and direction in regard to residential lanes, service lanes and private ways:

4.20.2 General

- 4.20.2.1 Alternative designs and construction of lanes and private ways may be allowed with the approval of the Engineering Manager.

4.21 Kerb and Channelling

This section sets out conditions for design and construction of kerb and channelling.

Mandatory Matters

The following matters are required in the design and construction of kerb and channelling associated with road construction:

4.21.1 General

- 4.21.1.1 Concrete restraint in the form of kerb and channel, nib kerb or mountable kerbing will be provided in all urban areas on both sides of the pavement formation to confine the pavement layers and control stormwater.
- 4.21.1.2 The minimum grade will be 1:250.
- 4.21.1.3 A minimum depth of 100mm of compacted base course will be placed under the kerb and channel. Compaction will be to a minimum of 98% of maximum dry density.

- 4.21.1.4 If unsuitable soil conditions are encountered at the base of kerb and channel excavations, the site will be trenched out below this depth and backfilled with gravel or other approved fill material in layers of a thickness that is compatible with the type of compaction equipment and material being used.
- 4.21.1.5 The concrete will comply with specified requirements of High-Grade Concrete in NZS 3104: 'Specification for concrete production'.
- 4.21.1.6 The profiles will conform to SD404.
- 4.21.1.7 Slip form kerb machines will be used where practical however when not suitable formwork for kerb and channel will be approved dressed timber, steel or aluminium alloy sections adequately oiled or otherwise treated to allow ease of striking without staining of the stripped concrete surface. All formwork will be accurately placed to the lines and levels of the works and will be such as to give the finished kerbs smooth and pleasing lines free of kinks and angles.
- 4.21.1.8 Control joints (for shrinkage control) will be installed at 5.0m intervals. Where the kerb intersects into crossover or undergoes a sharp change in direction the first shrinkage control will be positioned at this point or no further than 2m from the point. The control joint will be provided by a knife-edge cutting while the concrete is still plastic to at least a quarter of the depth of the concrete thickness.
- 4.21.1.9 The contractor must manage early concrete setting to avoid shrinkage cracking occurring between control joints. If the kerb is adjacent to a concrete footpath, then the control joint will coincide with the concrete footpath joints.
- 4.21.1.10 Kerb entries can only be installed with the Engineering Manager's approval.
- 4.21.1.11 Kerbs and channels will be finished such that on straight portions there is no deviation of more than 5mm within the length of a 3m straight edge; nor a deviation of more than 5mm from the line and level.
- 4.21.1.12 Kerbing and channelling be finished with a steel float and any concrete work showing honeycombing or scale in the face is to be removed and replaced.
- 4.21.1.13 All repairs to damaged kerb must be made prior to footpath surfacing.
- 4.21.1.14 Kerb crossings will be designed and constructed in accordance with SD404 and SD405.
- 4.21.1.15 When constructing curves, the use of regular forms to produce a chorded effect will not be accepted.
- 4.21.1.16 Changes of grade will be made with a smooth vertical curve, and horizontal curves will be circular or transition as required by section 4.8.4.

4.21.2 Benchmarks

- 4.21.2.1 The Designer will install Councils' standard benchmark plaques on the top of the kerb. A minimum of one plaque will be installed in each new street, at maximum intervals of 300m.
- 4.21.2.2 Where a plaque is installed to meet the requirement of Land Information NZ (LINZ) and it is installed on top of the kerb, this may be used as the benchmark and the Nelson City Council or Tasman District Council plaque omitted.

4.21.2.3 The proposed location will be shown on the engineering plans. The Designer will establish a reduced level and coordinates on each new benchmark and show this on the as-built plans to two decimal places.

4.21.2.4 Benchmark plaques will be supplied by the Council at no cost to the Designer.

Good Practice

The following matters provide additional guidance and direction regarding kerbing and channelling:

4.21.3 General

4.21.3.1 Horizontal or vertical curves of less than 6m radius will be constructed using special *in situ* formwork.

4.21.3.2 Where a subdivision is staged, the Designer may not be required to install a benchmark in each stage.

4.22 Paths

The following requirements relate to the construction of public accessways, footpaths and cycle facilities.

Mandatory Matters

The following construction standards apply to all paths including footpaths, paths in roads, public accessway links between roads, public accessways linking roads to reserves, paths in reserves and cycle facilities:

4.22.1 General

4.22.1.1 Paths must have a durable non-skid surface.

4.22.1.2 The path surface will be concrete, asphaltic concrete or an alternative surface where specifically approved by the Engineering Manager.

4.22.1.3 Where a footpath is constructed and there is a mountable kerb, or cut down kerb around the head of the cul-de-sac, both will be designed to carry the same vehicle loadings as the carriageway. Refer to 4.21.1.14 Kerb Crossings.

4.22.1.4 The path pavement will be designed in accordance with recognised techniques that include but are not limited to those listed below:

- a) CBR Method (CBR Design curves are given on SD402);
- b) Scala/Dynamic Cone Penetrometer (Design curves are given on SD403).

4.22.1.5 Footpaths and cycle facilities will be continuous across private accesses to ensure priority to footpath and cycle facility users is reinforced as required by section 4.10.1.3.

4.22.2 Concrete Paths

4.22.2.1 The minimum construction is to be 100mm thickness of reinforced 27.5 MPa at 28 days concrete. The surface will be broom finish, or another equivalent non-skid surface.

- 4.22.2.2 Residential entrance slabs will be increased to a minimum of 150mm thick for full width of crossing including side ramps.
- 4.22.2.3 Commercial entrance slabs will have a minimum of 200mm thickness of 27.5 MPa at 28 days concrete and will be reinforced with one layer of 665 WWF placed 50mm from bottom edge of concrete.
- 4.22.2.4 Industrial entrance slabs will have a minimum thickness of 300mm of 27.5 MPa at 28 days concrete and will be reinforced with two layers of 665 WWF reinforcing mesh. The two layers of mesh will be placed 200mm apart with each layer having 50mm cover from the outside surface of the concrete.
- 4.22.2.5 Construction joints are required at 5m intervals, and on both sides of entrance slabs. Refer to SD406 for full details.

4.22.3 Asphaltic Concrete Paths

- 4.22.3.1 The minimum construction is 25mm compacted depth of asphaltic concrete paving complying with NZTA Specification M/10 Table 3.2 'DG7'. The binder will be 80/100-penetration bitumen or as agreed with the Designer over a tack coat prior to paving.
- 4.22.3.2 Path edge restraint will be constructed both sides and will be either:
 - a) A ground treated (H4) timber batten 100mm x 25mm minimum pegged along the edges of the path with the top of the batten at finished level and will remain intact after the completion of the work. Refer to SD407; or
 - b) Or concrete kerb, nib or similar in accordance with SD404.
- 4.22.3.3 Joints in the asphalt surfacing will be either saw cut or formed to produce a neat straight line at right angles to the edge of the footpath and a flush smooth finish to the surface of the footpath. Joints will have a tack coat applied.
- 4.22.3.4 Asphaltic Concrete is not permitted for Commercial and Industrial entrances.

4.22.4 Acceptance Criteria

- 4.22.4.1 At no point on the finished basecourse surface will the Clegg Impact Value be less than 25 (after four (4) blows) for footpaths and residential vehicle access points, and 35 (after four (4) blows) for commercial vehicle access points.
- 4.22.4.2 The surface of the finished path will be such that when a 3m long straight edge is placed across the footpath no area deviates from the straight edge by more than 5mm. The edge of the path will not deviate by more than 5mm from the line and levels shown on the approved Engineering Drawings.
- 4.22.4.3 Where adjacent to a kerb, nib or similar the surface of the path will be flush with or no more than 5mm above the finished level of the concrete.
- 4.22.4.4 Note: also Chapter 8 section 8.5.2 and SD803, SD804 and SD805 regarding footpath reinstatement.

Appendix A Form 1 – RAMM Update Sheet

FORM 1—RAMM UPDATE SHEET - NEW OR RECONSTRUCTED ROADS

RECORDED BY _____ (Name) OF _____ (Company) DATE ____/____/____

ROAD NAME _____

(Distance in m) _____ (Circle one or two) (Intersecting road name) _____

START OF SECTION IS _____ m TO THE NORTH / SOUTH / WEST / EAST OF _____ INTERSECTION

END OF SECTION IS _____ m TO THE NORTH / SOUTH / WEST / EAST OF _____ INTERSECTION

SECTION LENGTH _____ m FULL WIDTH

SECTION WIDTH _____ m CONTRACT No. _____

NEW OR EXISTING SUBGRADE																																				
<p>1</p> <p>THE SUBGRADE IS <input checked="" type="checkbox"/> RECONSTRUCTED <input checked="" type="checkbox"/> UNDISTURBED</p> <p>SUBGRADE COLOUR _____</p> <p>SUBGRADE MAXIMUM STONE SIZE _____ mm</p> <p>IF SUBGRADE IS NEW, STATE:</p> <p>SUBGRADE LAYER THICKNESS _____ mm</p> <p>WHETHER SUBGRADE IS NEW OR EXISTING, SHOW THE SOIL TYPE:</p> <table style="width:100%;"> <tr> <td style="width:50%;">MAJOR PORTION</td> <td style="width:50%;">SUBORDINATE PORTION</td> </tr> <tr> <td><input checked="" type="checkbox"/> GRAVEL</td> <td><input checked="" type="checkbox"/> CLAYEY</td> </tr> <tr> <td><input type="checkbox"/> SAND</td> <td><input type="checkbox"/> SILTY E.G., SILTY CLAY</td> </tr> <tr> <td><input type="checkbox"/> SILT</td> <td><input type="checkbox"/> SANDY</td> </tr> <tr> <td><input type="checkbox"/> CLAY</td> <td><input type="checkbox"/> GRAVELLY</td> </tr> </table>	MAJOR PORTION	SUBORDINATE PORTION	<input checked="" type="checkbox"/> GRAVEL	<input checked="" type="checkbox"/> CLAYEY	<input type="checkbox"/> SAND	<input type="checkbox"/> SILTY E.G., SILTY CLAY	<input type="checkbox"/> SILT	<input type="checkbox"/> SANDY	<input type="checkbox"/> CLAY	<input type="checkbox"/> GRAVELLY	<p>2 SHOW SOIL STRENGTH:</p> <p>IF SUBGRADE IS MOSTLY CLAY, SILT OR SAND:</p> <table style="width:100%;"> <tr><td><input checked="" type="checkbox"/> Very soft</td><td>Exudes between fingers when squeezed</td></tr> <tr><td><input type="checkbox"/> Soft</td><td>Easily indented by fingers</td></tr> <tr><td><input type="checkbox"/> Firm</td><td>Indented only by strong finger pressure</td></tr> <tr><td><input type="checkbox"/> Stiff</td><td>Indented by thumb pressure</td></tr> <tr><td><input type="checkbox"/> Very stiff</td><td>Indented by thumbnail</td></tr> <tr><td><input type="checkbox"/> Hard</td><td>Difficult to indent by thumbnail</td></tr> </table> <p>OR...</p> <p>IF SUBGRADE IS MOSTLY SAND & GRAVEL:</p> <table style="width:100%;"> <tr><td><input checked="" type="checkbox"/> Loosely packed</td><td>Can remove by hand or easily by shovel</td></tr> <tr><td><input type="checkbox"/> Tightly packed</td><td>Pick required for removal</td></tr> </table> <p>3 SHOW CBR TEST RESULT (IF APPLICABLE):</p> <table style="width:100%;"> <tr><td><input checked="" type="checkbox"/> SOAKED CBR</td><td>CBR</td><td>_____</td></tr> <tr><td><input type="checkbox"/> INSITU CBR</td><td></td><td></td></tr> <tr><td><input type="checkbox"/> STABILISED</td><td></td><td></td></tr> </table>	<input checked="" type="checkbox"/> Very soft	Exudes between fingers when squeezed	<input type="checkbox"/> Soft	Easily indented by fingers	<input type="checkbox"/> Firm	Indented only by strong finger pressure	<input type="checkbox"/> Stiff	Indented by thumb pressure	<input type="checkbox"/> Very stiff	Indented by thumbnail	<input type="checkbox"/> Hard	Difficult to indent by thumbnail	<input checked="" type="checkbox"/> Loosely packed	Can remove by hand or easily by shovel	<input type="checkbox"/> Tightly packed	Pick required for removal	<input checked="" type="checkbox"/> SOAKED CBR	CBR	_____	<input type="checkbox"/> INSITU CBR			<input type="checkbox"/> STABILISED		
MAJOR PORTION	SUBORDINATE PORTION																																			
<input checked="" type="checkbox"/> GRAVEL	<input checked="" type="checkbox"/> CLAYEY																																			
<input type="checkbox"/> SAND	<input type="checkbox"/> SILTY E.G., SILTY CLAY																																			
<input type="checkbox"/> SILT	<input type="checkbox"/> SANDY																																			
<input type="checkbox"/> CLAY	<input type="checkbox"/> GRAVELLY																																			
<input checked="" type="checkbox"/> Very soft	Exudes between fingers when squeezed																																			
<input type="checkbox"/> Soft	Easily indented by fingers																																			
<input type="checkbox"/> Firm	Indented only by strong finger pressure																																			
<input type="checkbox"/> Stiff	Indented by thumb pressure																																			
<input type="checkbox"/> Very stiff	Indented by thumbnail																																			
<input type="checkbox"/> Hard	Difficult to indent by thumbnail																																			
<input checked="" type="checkbox"/> Loosely packed	Can remove by hand or easily by shovel																																			
<input type="checkbox"/> Tightly packed	Pick required for removal																																			
<input checked="" type="checkbox"/> SOAKED CBR	CBR	_____																																		
<input type="checkbox"/> INSITU CBR																																				
<input type="checkbox"/> STABILISED																																				

4 NEW SUBBASE (AP65-AP75)	5 NEW BASECOURSE (AP40)
SUBBASE LAYER THICKNESS _____ mm	BASECOURSE LAYER THICKNESS _____ mm
MAXIMUM STONE SIZE _____ mm	MAXIMUM STONE SIZE _____ mm
SOURCE _____	SOURCE _____
BASECOURSE SPECIFICATION <input checked="" type="checkbox"/> TNZ M/4 <input type="checkbox"/> OTHER (SPECIFY): _____	

6 GEOGRID AND GEOTEXTILE

TYPE _____

7 NEW SURFACE

SURFACING CONTRACTOR _____

<input checked="" type="checkbox"/> CHIPSEAL <input type="checkbox"/> ASPHALT <input type="checkbox"/> FRICTION COURSE <input type="checkbox"/> SLURRY <input type="checkbox"/> CONCRETE <input type="checkbox"/> NOT SEALED <input type="checkbox"/> OTHER	<table border="1" style="width:100%; border-collapse: collapse;"> <thead> <tr> <th>ALD</th> <th>THICKNESS</th> <th>STONE SIZE</th> </tr> </thead> <tbody> <tr> <td>mm</td> <td>mm</td> <td>GRADE</td> </tr> <tr> <td></td> <td>mm</td> <td>mm</td> </tr> <tr> <td></td> <td>mm</td> <td>mm</td> </tr> <tr> <td></td> <td>mm</td> <td></td> </tr> </tbody> </table>	ALD	THICKNESS	STONE SIZE	mm	mm	GRADE		mm	mm		mm	mm		mm		<table style="width:100%;"> <tr> <th>BINDER</th> <th>QUANTITY</th> <th>TYPE</th> </tr> <tr> <td>CUTTER</td> <td>pph</td> <td></td> </tr> <tr> <td>ADHESION AGENT</td> <td>pph</td> <td></td> </tr> <tr> <td>FLUX</td> <td>pph</td> <td></td> </tr> <tr> <td>ADDITIVES</td> <td>pph</td> <td></td> </tr> <tr> <td>POLYMER</td> <td>%</td> <td></td> </tr> </table> <p>BINDER RESIDUAL APPLICATION RATE _____ l/m²</p>	BINDER	QUANTITY	TYPE	CUTTER	pph		ADHESION AGENT	pph		FLUX	pph		ADDITIVES	pph		POLYMER	%	
ALD	THICKNESS	STONE SIZE																																	
mm	mm	GRADE																																	
	mm	mm																																	
	mm	mm																																	
	mm																																		
BINDER	QUANTITY	TYPE																																	
CUTTER	pph																																		
ADHESION AGENT	pph																																		
FLUX	pph																																		
ADDITIVES	pph																																		
POLYMER	%																																		

NELSON CITY COUNCIL USE ONLY RAD_n867318

Data entered into RAMM? Entered by: _____ Date: _____

GRADING ENVELOPE AP65

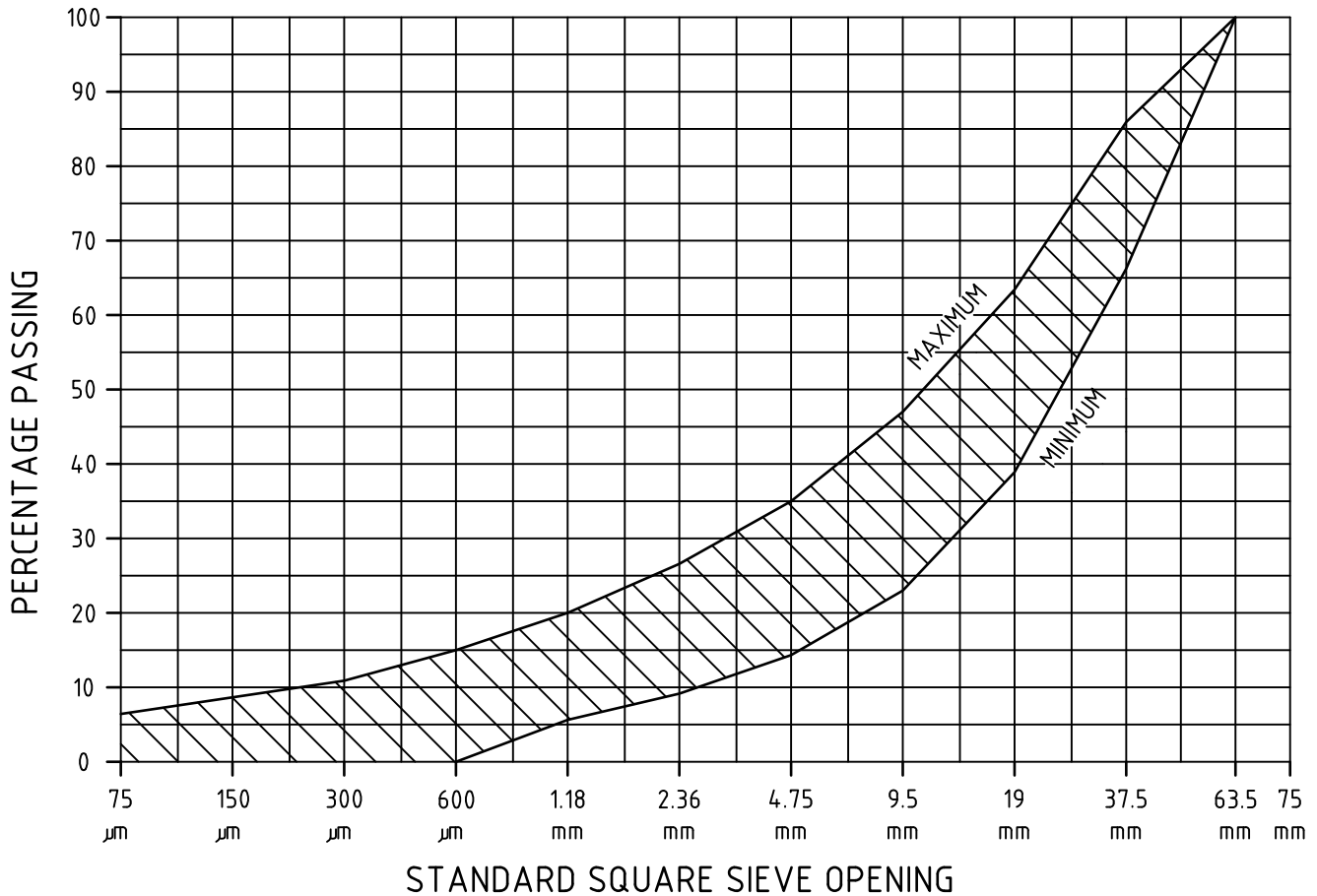

A. PROPORTION OF BROKEN ROCK:

THE PERCENTAGE BY WEIGHT OF MATERIAL IN EACH OF THE FIVE FRACTIONS BETWEEN THE 63.5mm AND 4.75mm SIEVES HAVING TWO OR MORE BROKEN FACES SHALL NOT BE LESS THAN 70%

B. CRUSHING RESISTANCE:

THE CRUSHING RESISTANCE SHALL NOT BE LESS THAN 110kN

C. WEATHERING RESISTANCE:

THE AGGREGATE SHALL FALL INTO ONE OF THE FOLLOWING WEATHERING RESISTANCE CATEGORIES:- AA AB AC BA BB CA.

D. SAND EQUIVALENT:

THE SAND EQUIVALENT SHALL NOT BE LESS THAN 25 WHEN THE AGGREGATE IS TESTED ACCORDING TO NZS 4407: 1991.

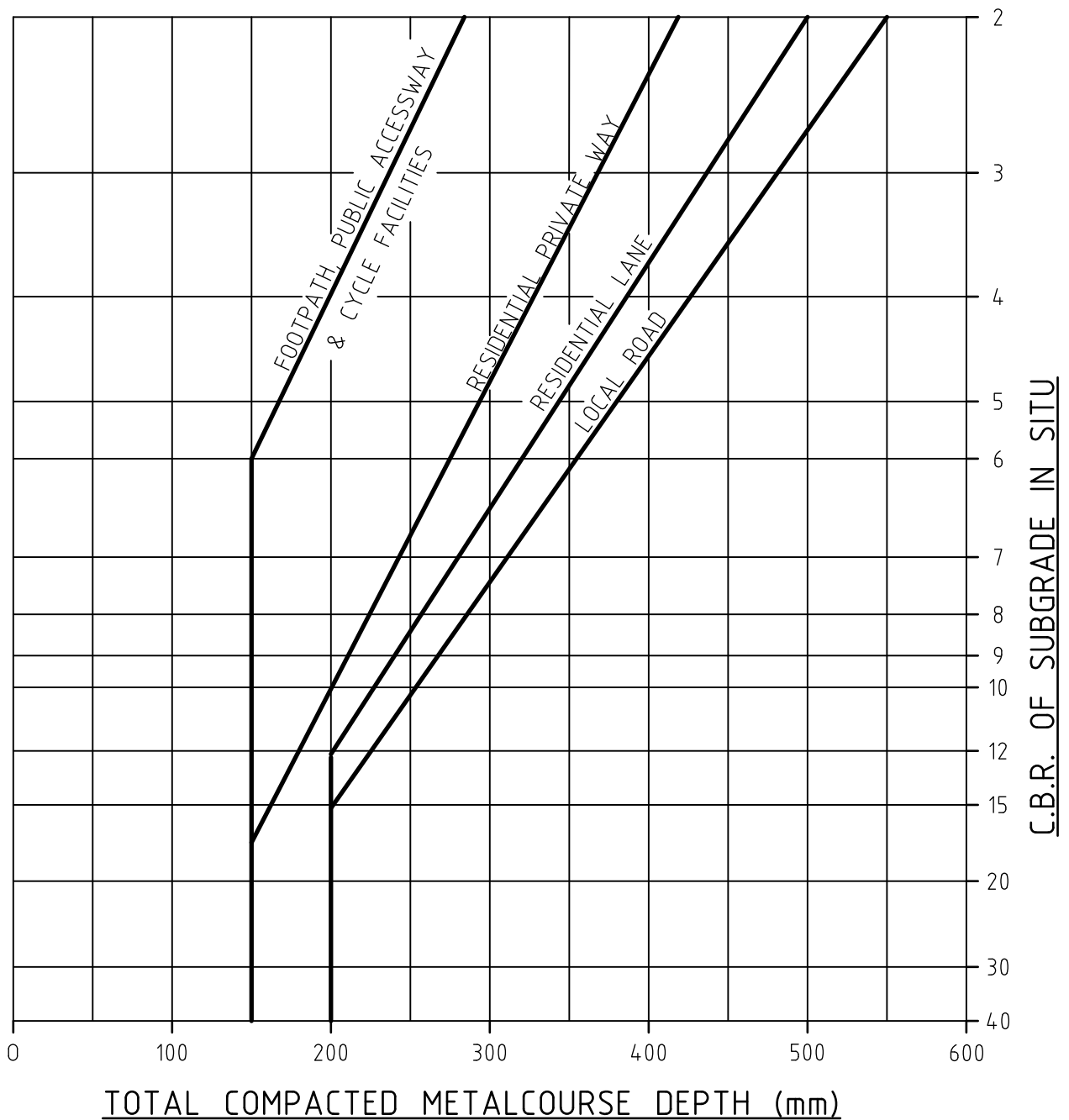

THE CLAY INDEX SHALL BE LESS THAN 4.0, AND PLASTICITY INDEX LESS THAN 5.0.

<p style="text-align: center;">NELSON CITY COUNCIL</p> <div style="text-align: center;"> </div> <p style="text-align: center; font-size: small;">GROUP MANAGER INFRASTRUCTURE, NELSON</p>	<h2 style="margin: 0;">65mm SUB-BASECOURSE AGGREGATE</h2>		
<p style="text-align: center;">TASMAN DISTRICT COUNCIL</p> <div style="text-align: center;"> </div> <p style="text-align: center; font-size: small;">ENGINEERING SERVICES MANAGER, TASMAN</p>	<p style="text-align: center;">DATE</p> <p style="text-align: center;">01/07/19</p>	<p style="text-align: center;">NELSON - TASMAN LAND DEVELOPMENT MANUAL</p>	401



NOTE:

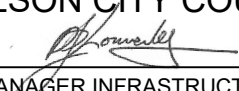

MINIMUM M/4 AP40 BASECOURSE LAYER REQUIRED IS 100mm FOR CONCRETE FOOTPATHS, 150mm FOR ASPHALTIC CONCRETE FOOTPATHS & RESIDENTIAL PRIVATE WAY'S, 200mm FOR ROADS & COMMERCIAL/INDUSTRIAL PRIVATE WAY'S

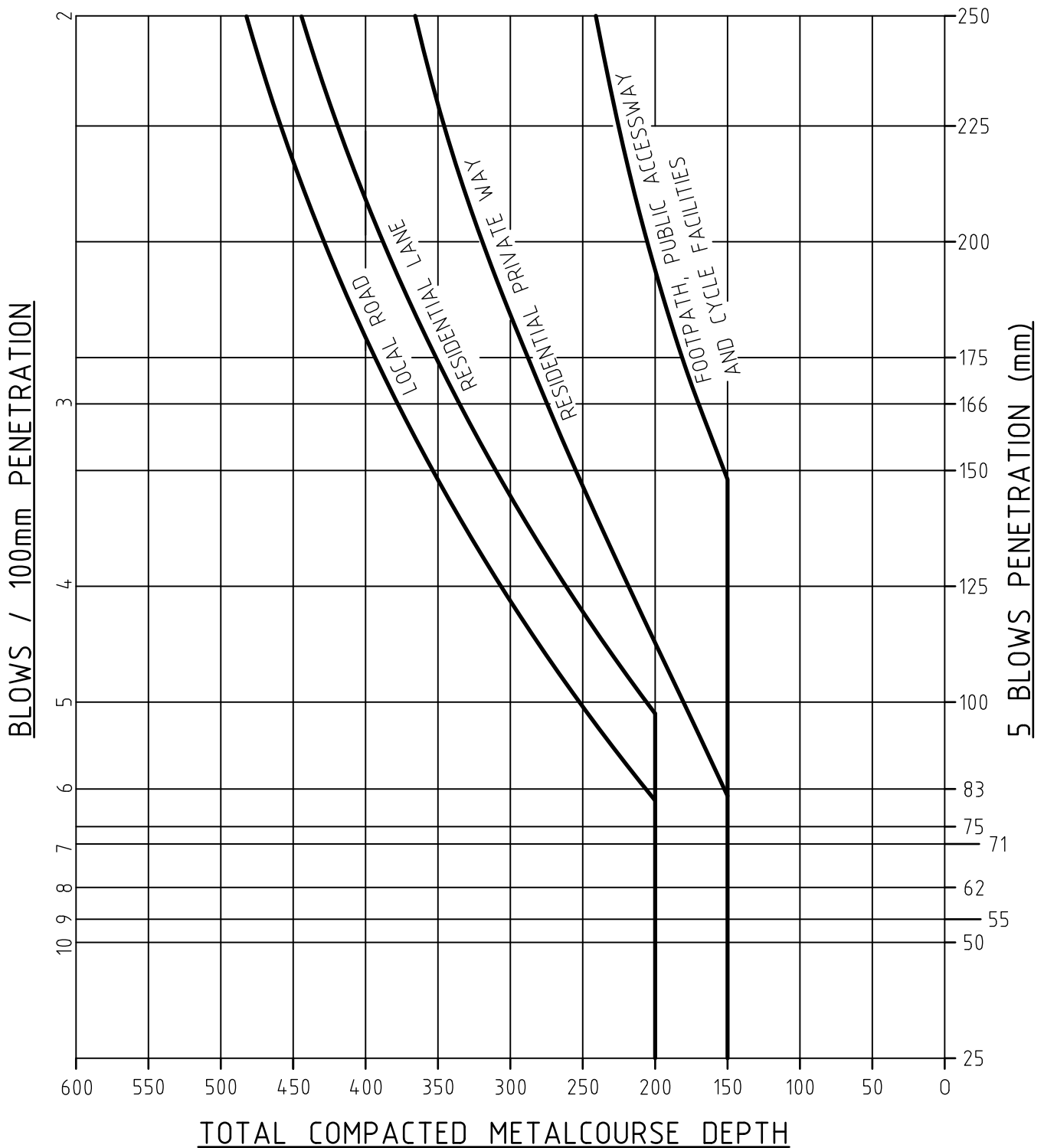
NELSON CITY COUNCIL  GROUP MANAGER INFRASTRUCTURE, NELSON		DESIGN GRAPH FOR LIGHT FLEXIBLE PAVEMENTS CBR METHOD	
TASMAN DISTRICT COUNCIL  ENGINEERING SERVICES MANAGER, TASMAN		DATE 01/07/19	NELSON - TASMAN LAND DEVELOPMENT MANUAL
			402

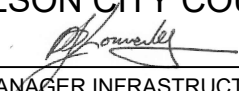

NOTE:

MINIMUM M/4 AP40 BASECOURSE LAYER REQUIRED IS 100mm FOR CONCRETE FOOTPATHS, 150mm FOR ASPHALTIC CONCRETE FOOTPATHS & RESIDENTIAL PRIVATE WAY'S, 200mm FOR ROADS & COMMERCIAL/INDUSTRIAL PRIVATE WAY'S

NELSON CITY COUNCIL  GROUP MANAGER INFRASTRUCTURE, NELSON		DESIGN GRAPH FOR LIGHT FLEXIBLE PAVEMENTS SCALA DYNAMIC CONE PENETROMETER	
TASMAN DISTRICT COUNCIL  ENGINEERING SERVICES MANAGER, TASMAN		DATE 01/07/19	NELSON - TASMAN LAND DEVELOPMENT MANUAL
			403

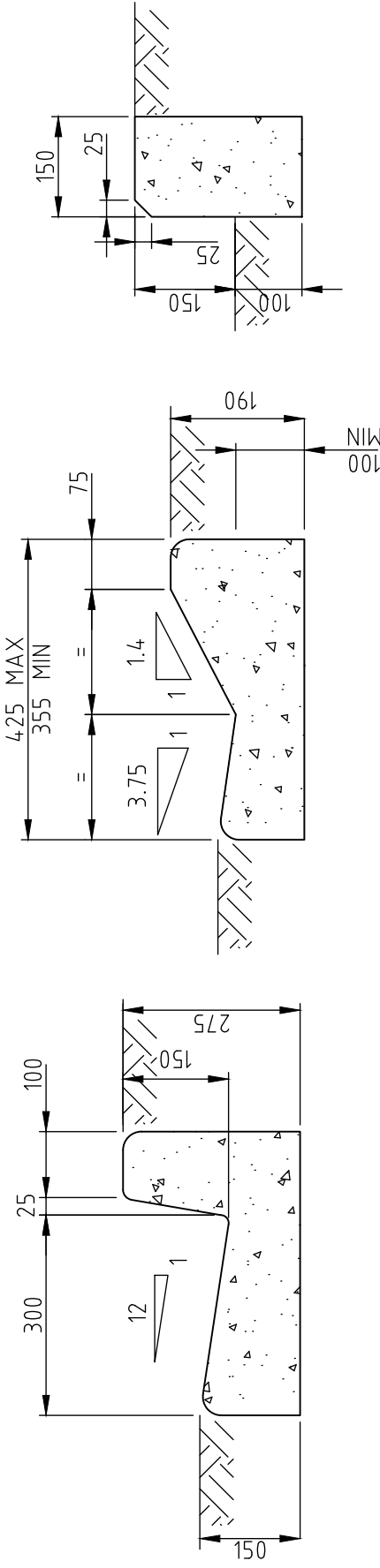

KERB & CHANNEL

MOUNTABLE KERB & CHANNEL

UNMOUNTABLE KERB

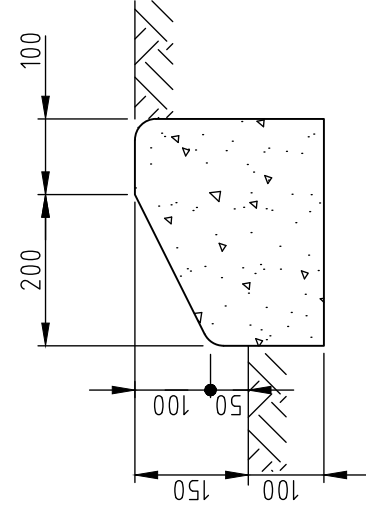

MOUNTABLE KERB

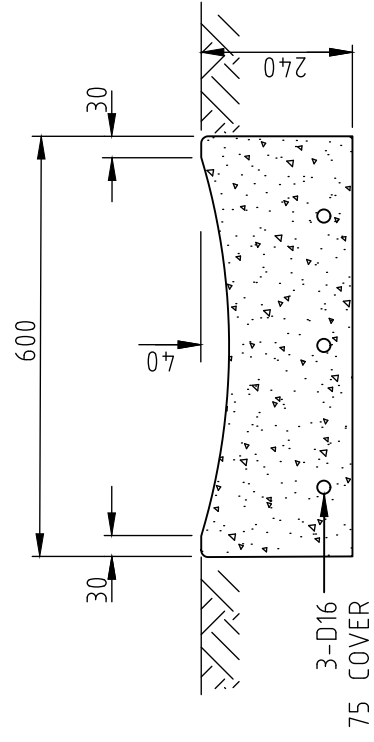

DISH CHANNEL

NOTE:

27.5 MPa CONCRETE
AT 28 DAYS MINIMUM

NELSON CITY COUNCIL
[Signature]
GROUP MANAGER INFRASTRUCTURE, NELSON

STANDARD KERB & CHANNEL PROFILES

TASMAN DISTRICT COUNCIL
[Signature]
ENGINEERING SERVICES MANAGER, TASMAN

DATE
01/07/19

NELSON - TASMAN
LAND DEVELOPMENT MANUAL

404

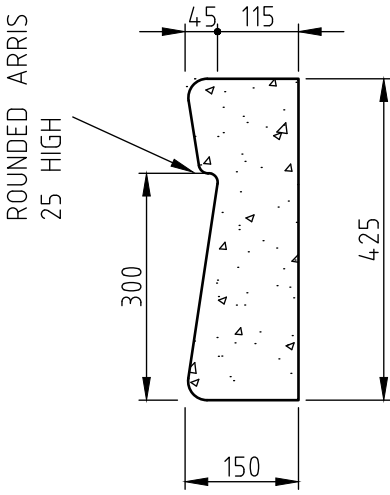

STANDARD RESIDENTIAL CROSSING

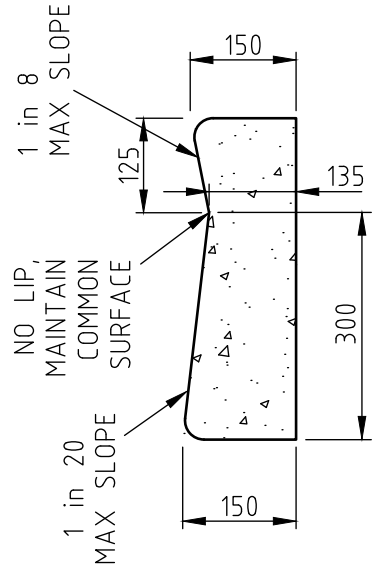
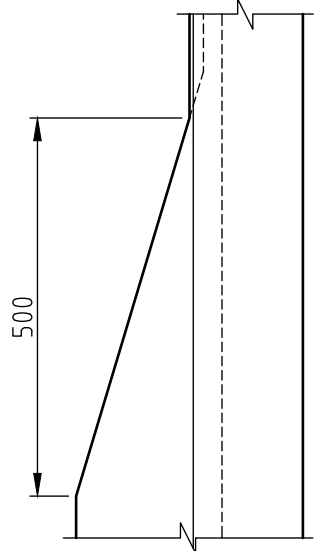

PRAM CROSSING

NOTE:

27.5 MPa CONCRETE
AT 28 DAYS MINIMUM

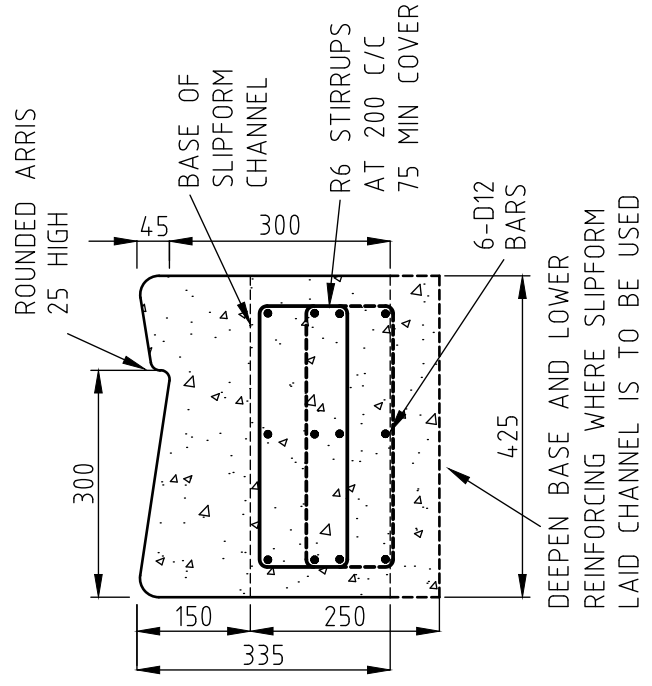

STANDARD INDUSTRIAL CROSSING

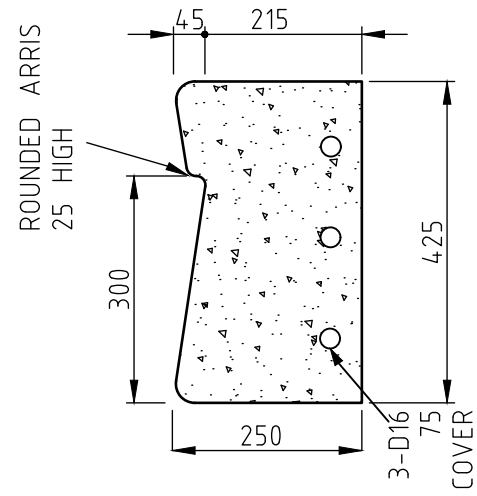
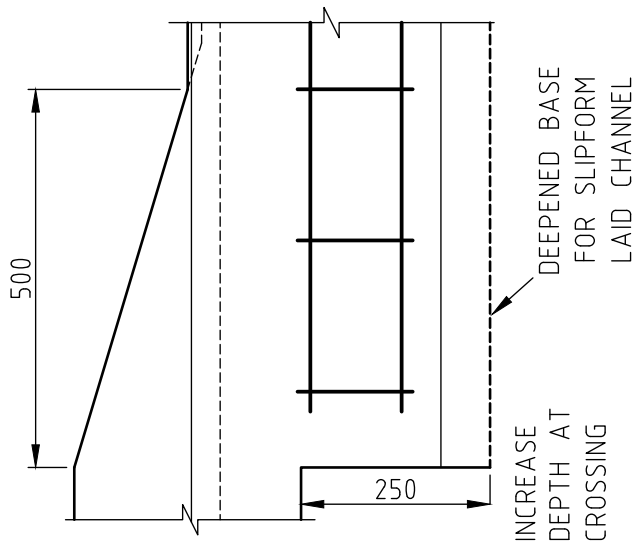

STANDARD COMMERCIAL CROSSING

NELSON CITY COUNCIL
[Signature]
GROUP MANAGER INFRASTRUCTURE, NELSON

STANDARD KERB & CHANNEL CROSSINGS

TASMAN DISTRICT COUNCIL
[Signature]
ENGINEERING SERVICES MANAGER, TASMAN

DATE
01/07/19

NELSON - TASMAN
LAND DEVELOPMENT MANUAL

405

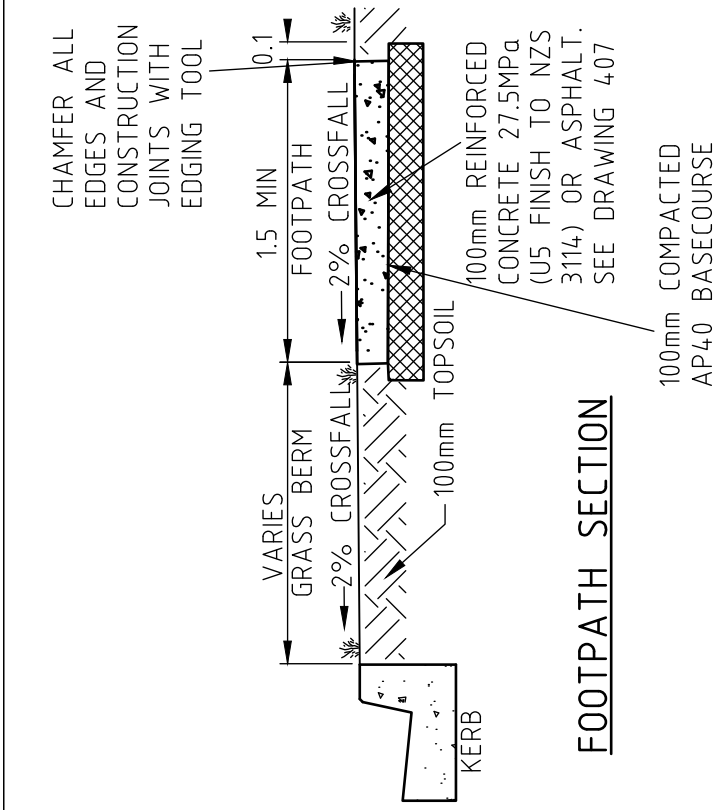
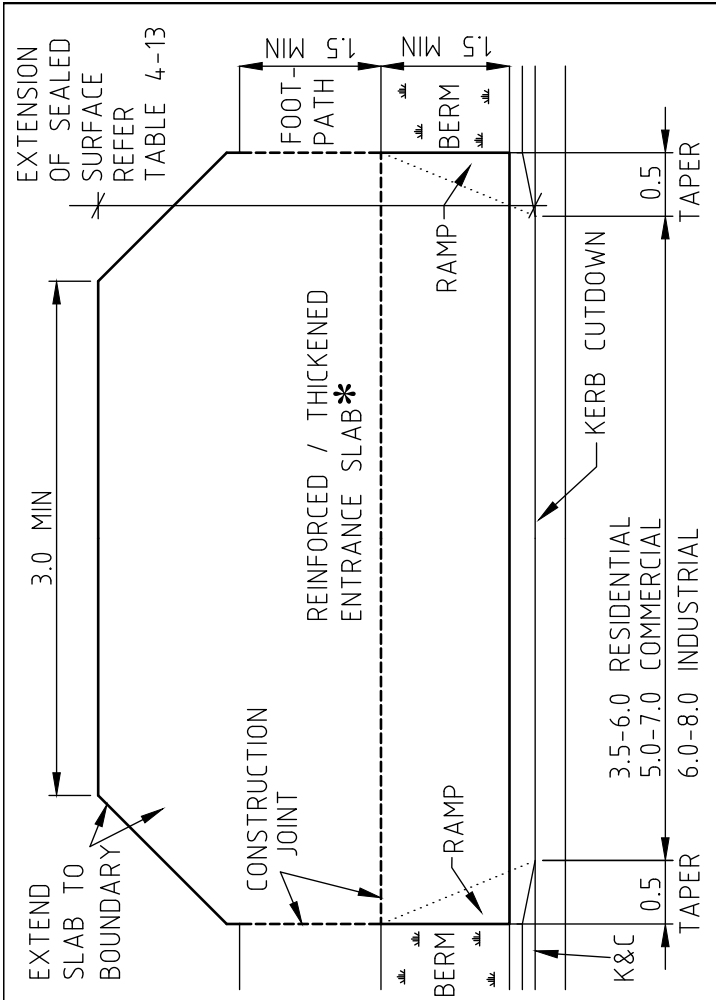

VEHICLE ENTRANCE PLAN

NOTE:

CONCRETE STRENGTH OF 27.5MPa IS EXPECTED AT 28 DAYS OF ALL CONCRETE USED IN COUNCIL'S INFRASTRUCTURE IN THIS LDM.

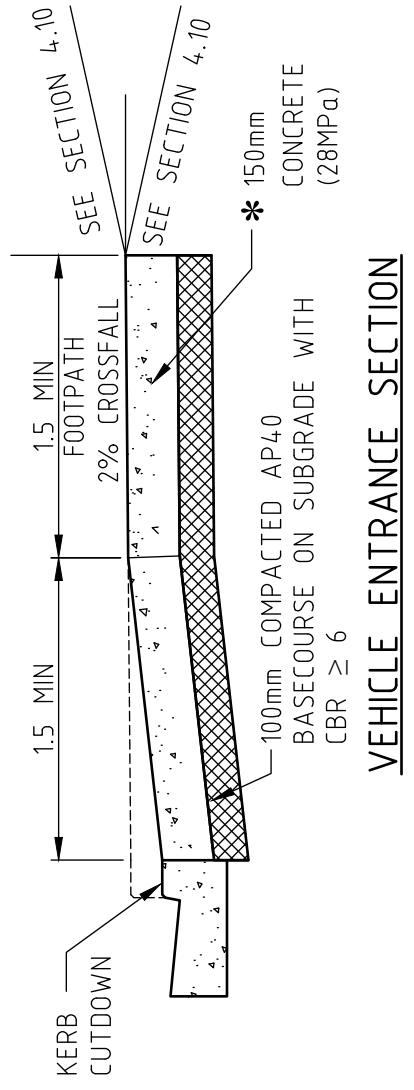

VEHICLE ENTRANCE SECTION

* NB

COMMERCIAL VEHICLE ENTRANCE
200mm DEPTH CONCRETE, 27.5MPa REINFORCED WITH ONE LAYER 665 WWF WITH 75mm COVER FROM UNDERSIDE OF CONCRETE SURFACE.

INDUSTRIAL VEHICLE ENTRANCE
300mm THICK CONCRETE, 27.5MPa WITH 2 LAYERS OF 665 WWF REINFORCING. WWF SHALL HAVE 200mm SEPARATION AND 75mm COVER.

NELSON CITY COUNCIL
GROUP MANAGER INFRASTRUCTURE, NELSON

TASMAN DISTRICT COUNCIL
ENGINEERING SERVICES MANAGER, TASMAN

1.5m WIDE FOOTPATH
OFFSET FROM KERB

DATE
01/07/19

NELSON - TASMAN
LAND DEVELOPMENT MANUAL

406

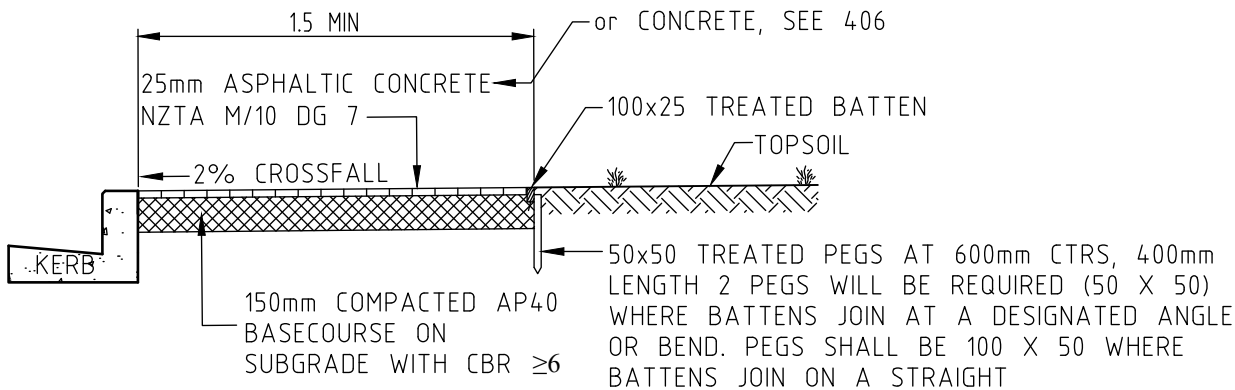

FOOTPATH SECTION

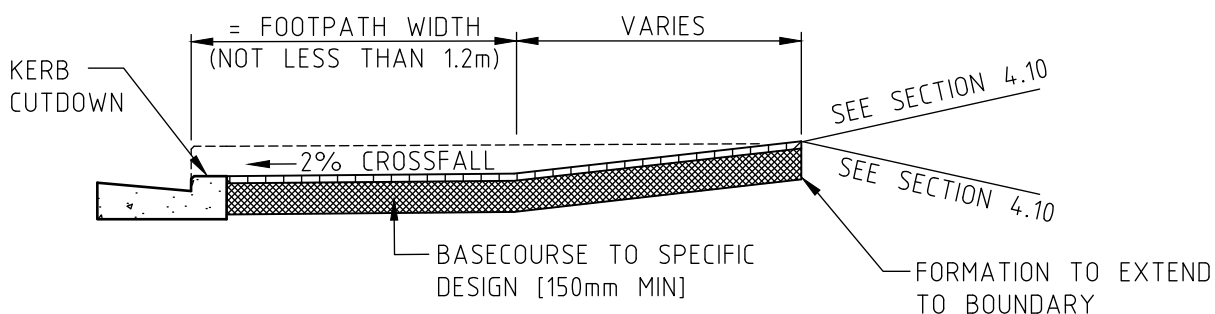

VEHICLE ENTRANCE SECTION

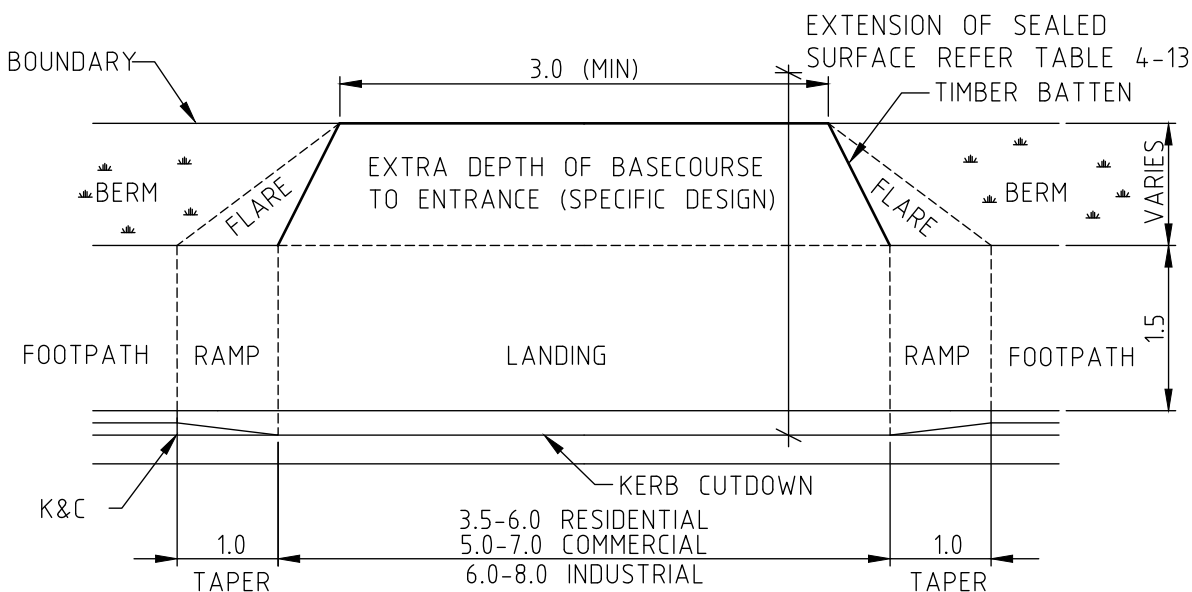

VEHICLE ENTRANCE PLAN

NOTES:

1. FOR ROADS WHERE THE VEHICLE DESIGN SPEED IS 40km/hr or LESS, AND THE FOOTPATH IS ADJACENT THE KERB OR BERM LESS THAN 1.5m, THEN FULL HEIGHT MOUNTABLE KERB & CHANNEL SHALL BE USED
2. VEHICLE ENTRANCE & FOOTPATH TRANSITION MUST COMPLY WITH FIGURE 15.1 & TABLE 15.2 OF THE LAND TRANSPORT NZ 'PEDESTRIAN PLANNING & DESIGN GUIDE'

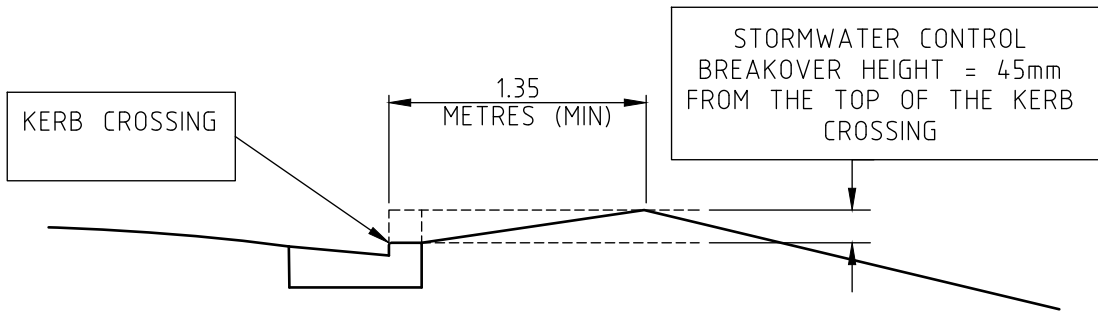

NELSON CITY COUNCIL GROUP MANAGER INFRASTRUCTURE, NELSON		1.5m WIDE FOOTPATH ADJACENT KERB (ONLY WITH COUNCIL APPROVAL)	
TASMAN DISTRICT COUNCIL ENGINEERING SERVICES MANAGER, TASMAN		DATE 01/07/19	NELSON - TASMAN LAND DEVELOPMENT MANUAL
			407

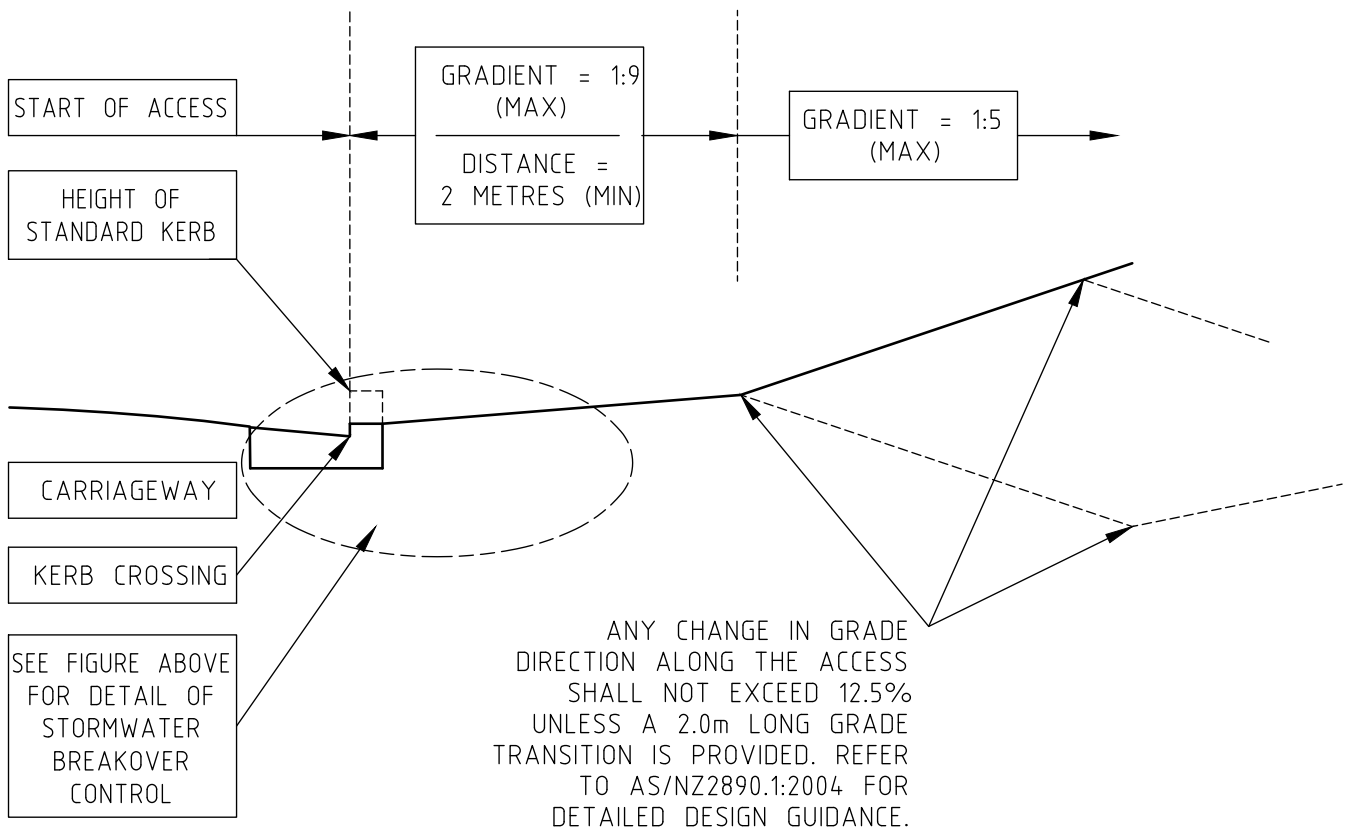

DIMENSIONS OF STORMWATER BREAKOVER CONTROL FOR ACCESSES BELOW THE ROAD

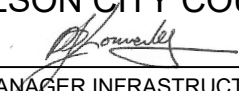

GRADIENT OF ACCESS AND BREAKOVER ANGLES FOR ACCESS TO SITES WHERE THERE IS NO EXISTING OR PROPOSED FOOTPATH

<p>NELSON CITY COUNCIL</p>  <p>GROUP MANAGER INFRASTRUCTURE, NELSON</p>	<p>ACCESS BREAKOVER ANGLES WHERE NO PROPOSED FOOTPATH</p>		
<p>TASMAN DISTRICT COUNCIL</p>  <p>ENGINEERING SERVICES MANAGER, TASMAN</p>	<p>DATE 01/07/19</p>	<p>NELSON - TASMAN LAND DEVELOPMENT MANUAL</p>	<p>408</p>

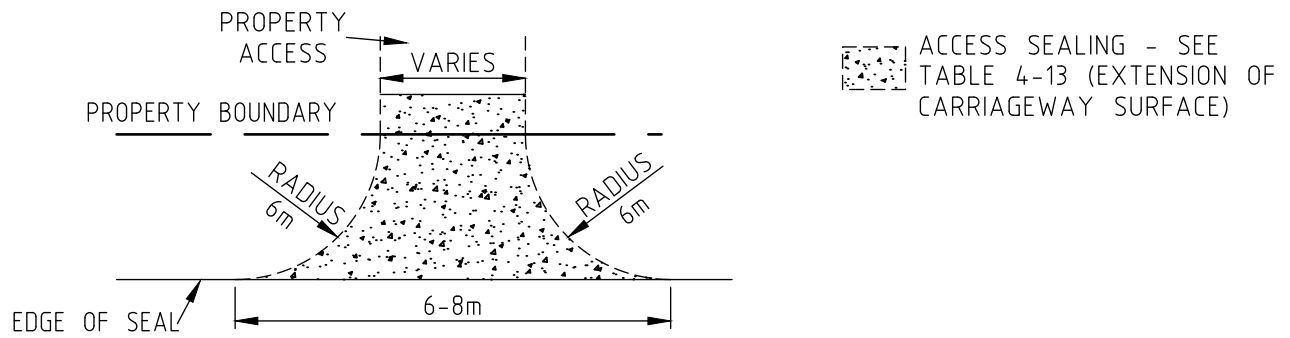

DIAGRAM 1: RURAL VEHICLE CROSSING FOR UP TO SIX DWELLINGS

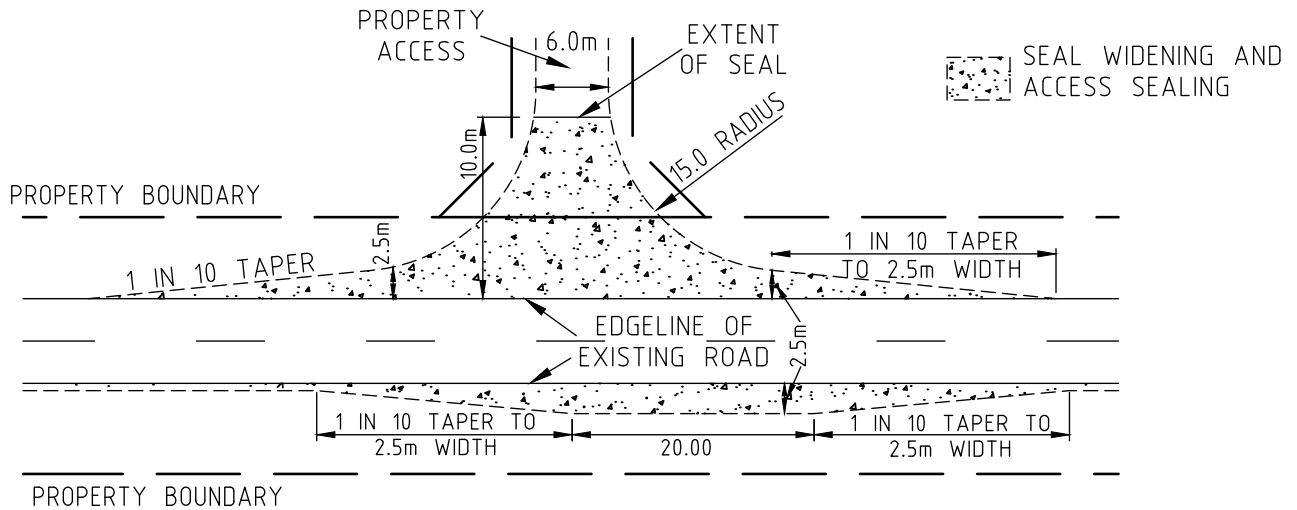

DIAGRAM 2: VEHICLE CROSSING FOR MORE THAN SIX DWELLINGS OR FOR A RURAL ACTIVITY

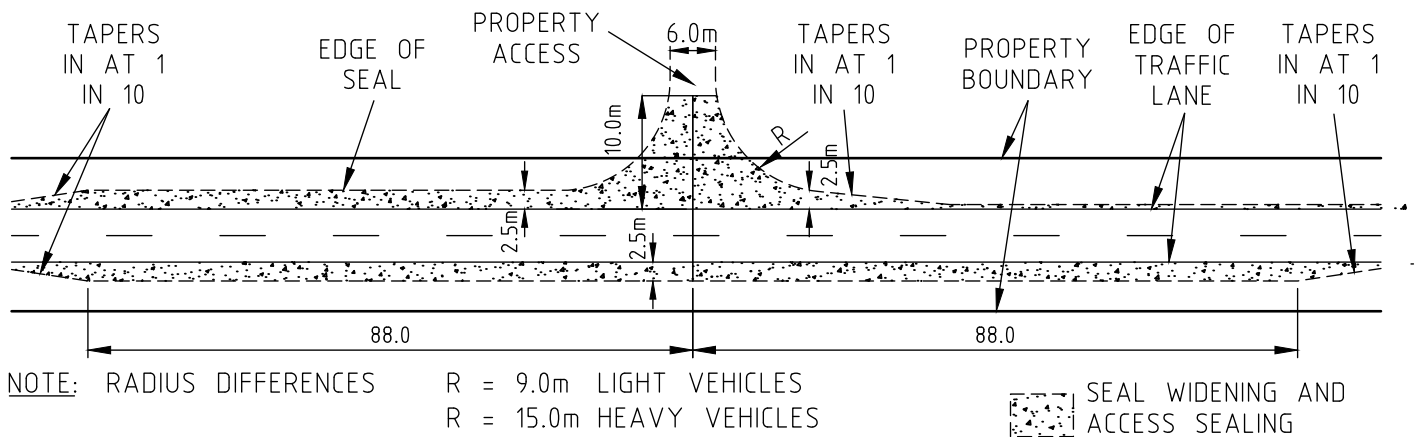

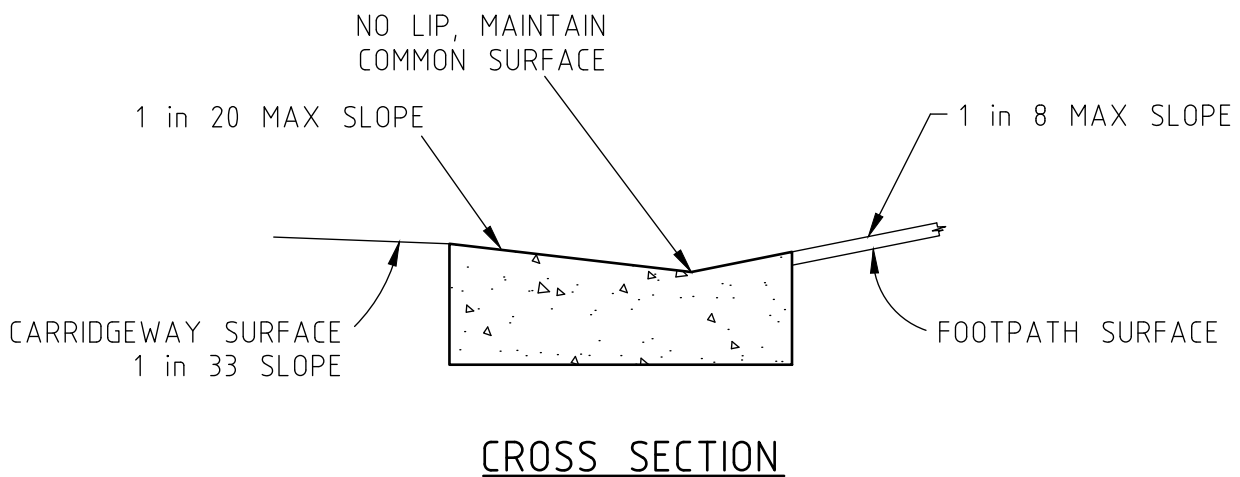
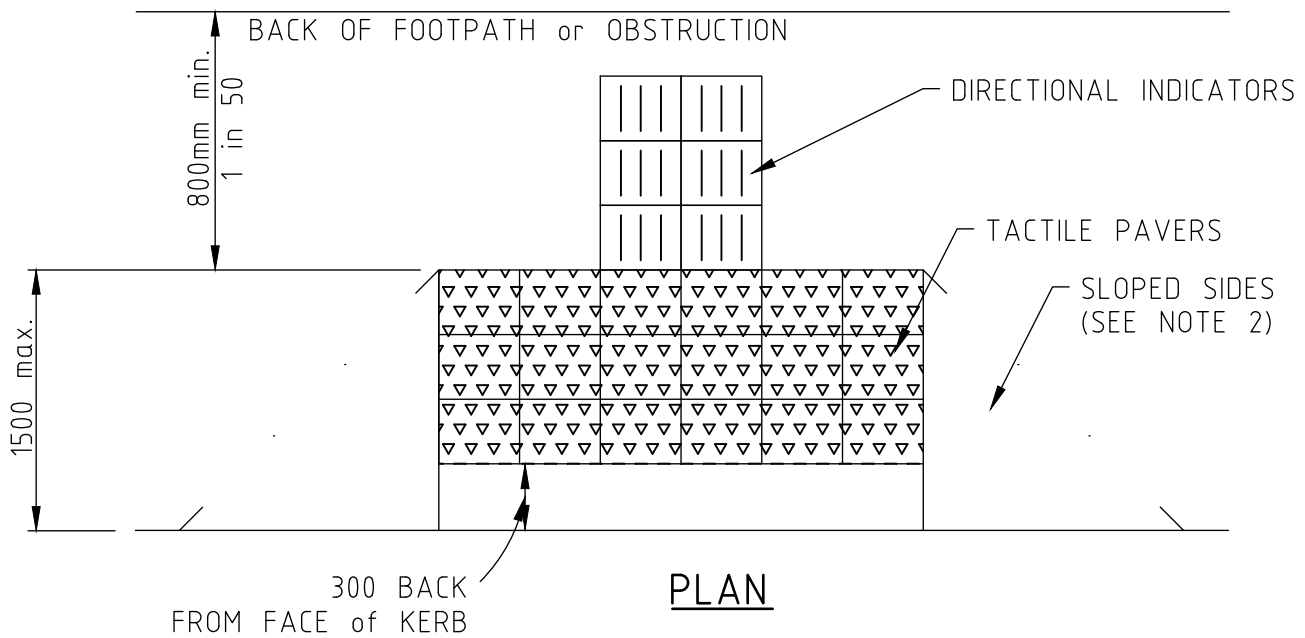

DIAGRAM 3: VEHICLE CROSSING FOR COMMERCIAL OR INDUSTRIAL ACTIVITY



NOTE: VEGETATION CLEARANCE BOTH SIDES OF ENTRANCEWAY TO ENHANCE SITE VISIBILITY.

NELSON CITY COUNCIL  GROUP MANAGER INFRASTRUCTURE, NELSON		RURAL ACCESS DETAILS	
TASMAN DISTRICT COUNCIL  ENGINEERING SERVICES MANAGER, TASMAN		DATE 01/07/19	NELSON - TASMAN LAND DEVELOPMENT MANUAL
			409



NOTES:

- FOR LAYOUT and INSTALLATION OF TACTILE PAVING & DIRECTIONAL INDICATORS, SEE SECTION 4.13.4
- SLOPED SIDES SHALL HAVE A MAXIMUM GRADIENT OF 1 in 8 WHERE ABUTTING A FOOTPATH. WHERE THE SLOPED SIDE ABUTS A BERM, THE GRADIENT CAN BE INCREASED TO 1 in 6

NELSON CITY COUNCIL  GROUP MANAGER INFRASTRUCTURE, NELSON		PEDESTRIAN KERB CROSSING AND RAMP	
TASMAN DISTRICT COUNCIL  ENGINEERING SERVICES MANAGER, TASMAN	DATE 01/07/19	NELSON - TASMAN LAND DEVELOPMENT MANUAL	410

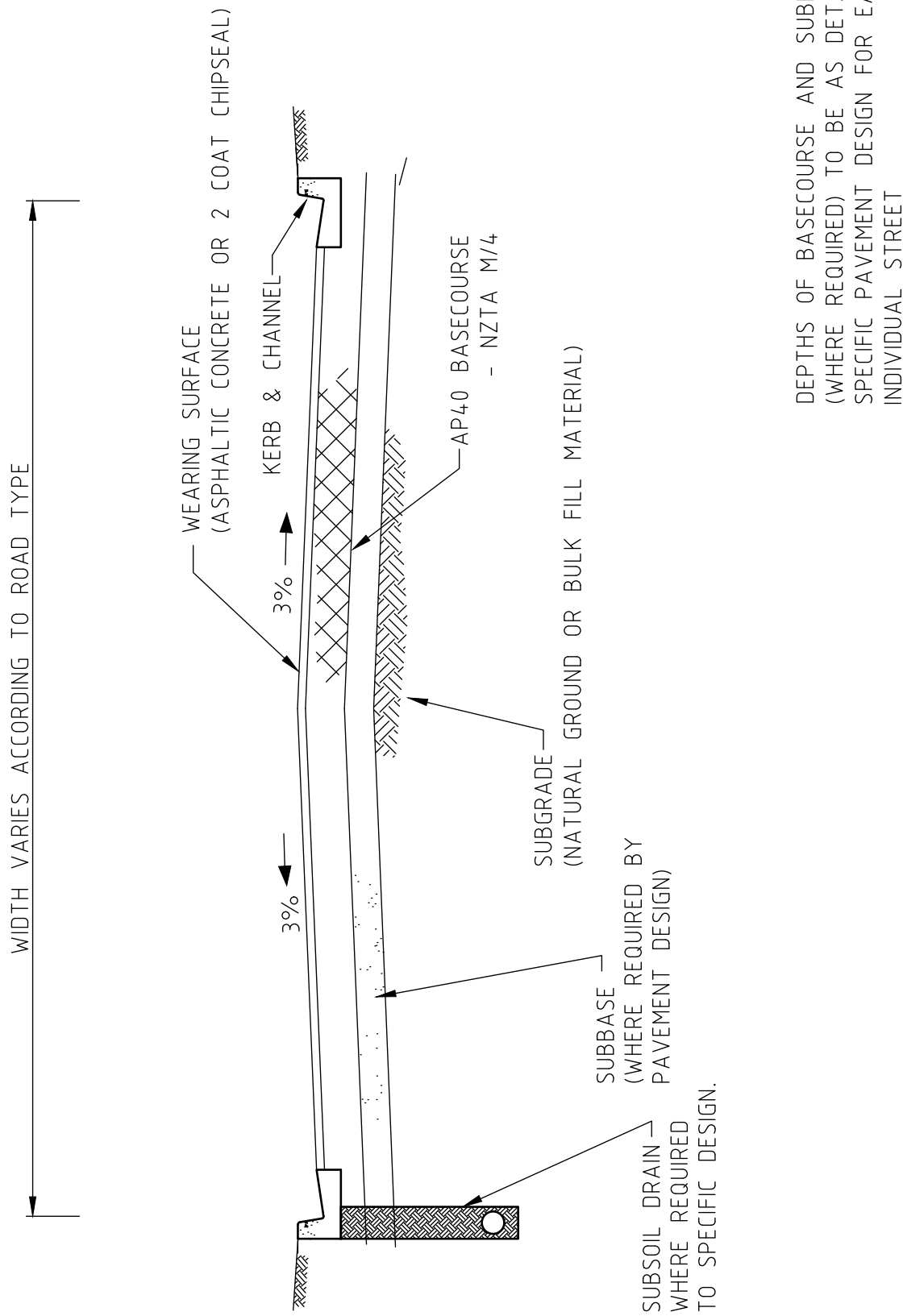

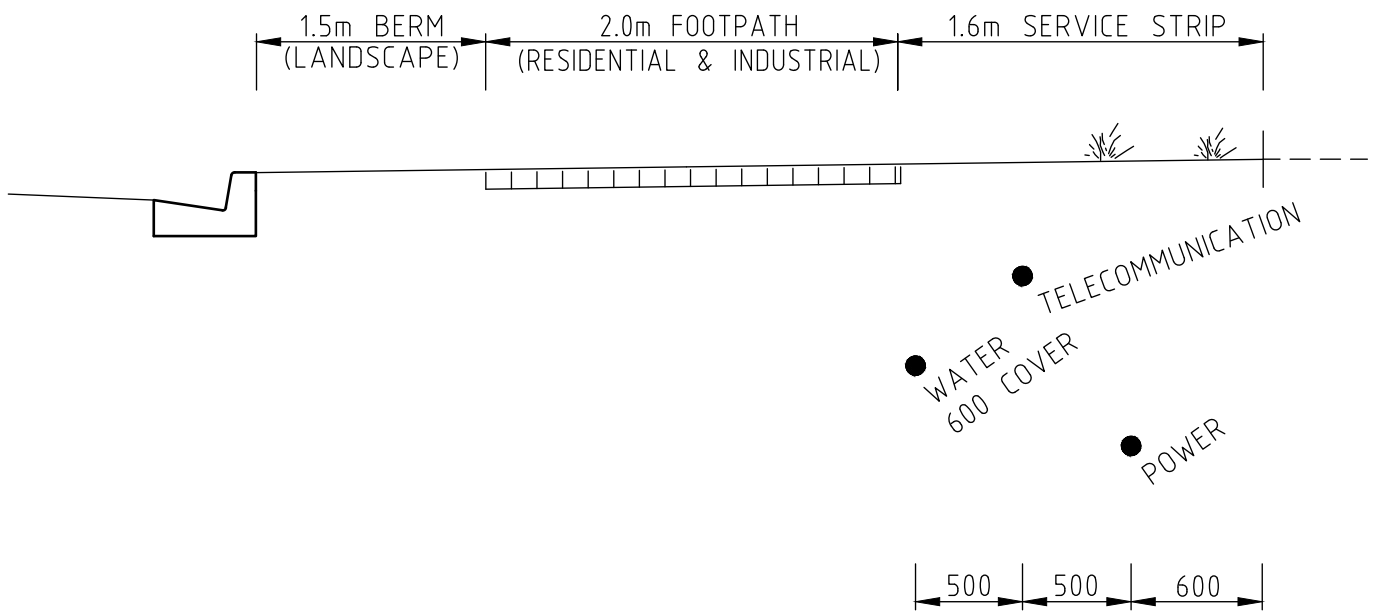
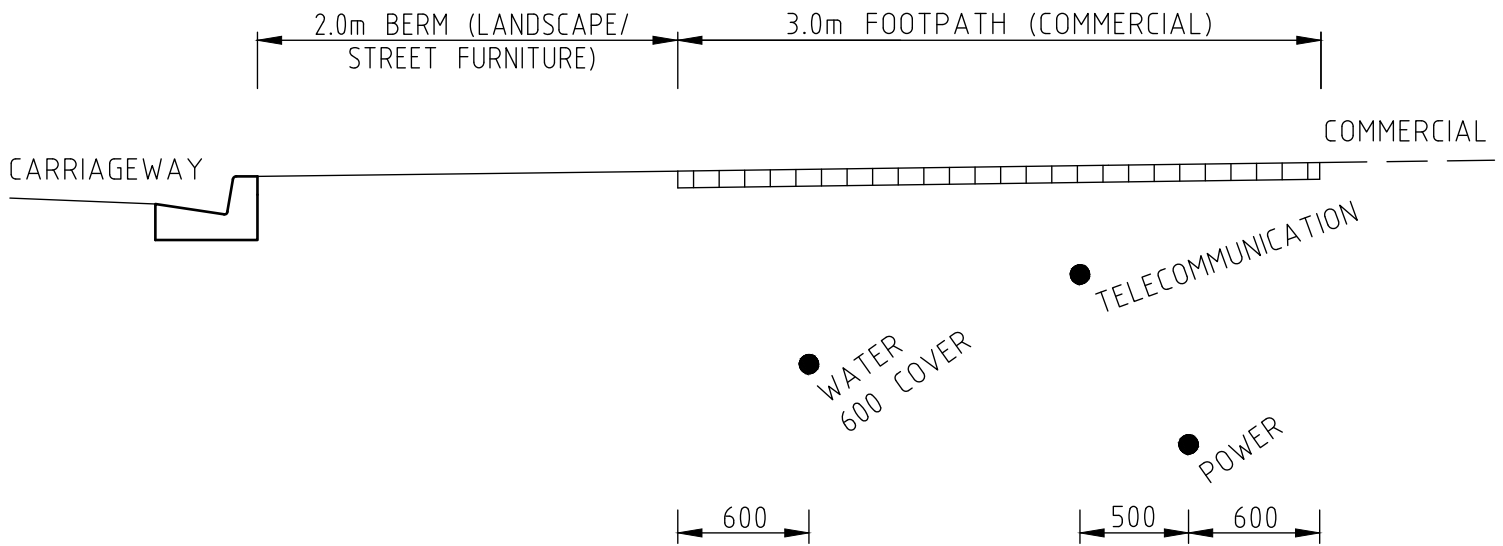

DEPTHS OF BASECOURSE AND SUBBASE
(WHERE REQUIRED) TO BE AS DETAILED IN
SPECIFIC PAVEMENT DESIGN FOR EACH
INDIVIDUAL STREET

<p>NELSON CITY COUNCIL</p> <p><i>[Signature]</i></p> <p>GROUP MANAGER INFRASTRUCTURE, NELSON</p>	<p>TYPICAL CROSS SECTION CARRIAGEWAY - URBAN ROADS</p>		
<p>TASMAN DISTRICT COUNCIL</p> <p><i>[Signature]</i></p> <p>ENGINEERING SERVICES MANAGER, TASMAN</p>	<p>DATE</p> <p>01/07/19</p>	<p>NELSON - TASMAN LAND DEVELOPMENT MANUAL</p>	<p>411</p>

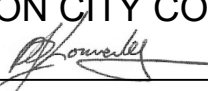

NOTES:

1. SERVICES BERM CAN BE REDUCED TO 0.5m WHERE SERVICES ARE UNDER THE FOOTPATH PROVIDED THEY DO NOT PRECLUDE THE INTRODUCTION OF STREET TREES
2. THE DEPTH OF CABLES MAY VARY. SEE SECTION 9 FOR POWER AND COMMUNICATION CABLE RETICULATION

<p>NELSON CITY COUNCIL</p>  <p>GROUP MANAGER INFRASTRUCTURE, NELSON</p>	<p>TYPICAL CROSS SECTIONS (BERMS) ARTERIAL AND PRINCIPAL ROADS</p>		
<p>TASMAN DISTRICT COUNCIL</p>  <p>ENGINEERING SERVICES MANAGER, TASMAN</p>	<p>DATE</p> <p>01/07/19</p>	<p>NELSON - TASMAN LAND DEVELOPMENT MANUAL</p>	<p>412</p>

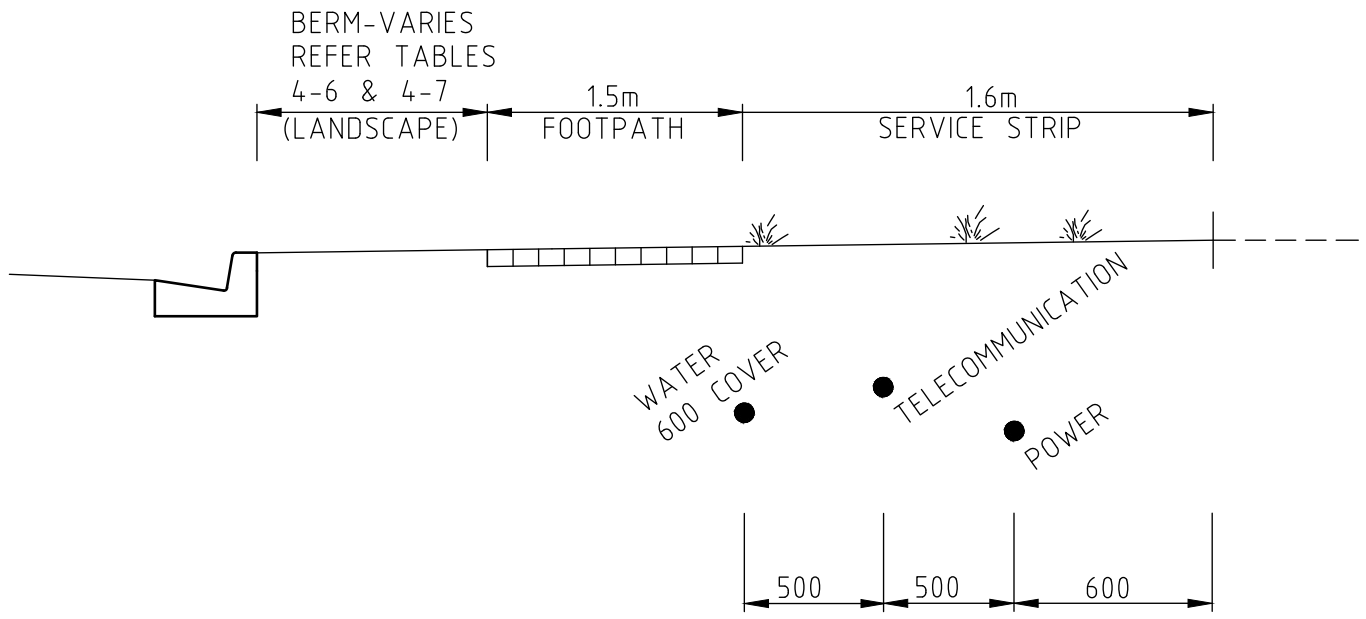

NOTES:

1. SERVICES BERM CAN BE REDUCED TO 0.5m WHERE SERVICES ARE LOCATED UNDER THE FOOTPATH PROVIDED THEY DO NOT PRECLUDE THE INTRODUCTION OF STREET TREES
2. THE DEPTH OF CABLES MAY VARY. SEE SECTION 9 FOR POWER AND COMMUNICATION CABLE RETICULATION

<p>NELSON CITY COUNCIL</p> <p><i>[Signature]</i></p> <p>GROUP MANAGER INFRASTRUCTURE, NELSON</p>		<p>TYPICAL CROSS SECTIONS (BERMS)</p> <p>COLLECTOR, SUB COLLECTOR & LOCAL ROADS</p>	
<p>TASMAN DISTRICT COUNCIL</p> <p><i>[Signature]</i></p> <p>ENGINEERING SERVICES MANAGER, TASMAN</p>	<p>DATE</p> <p>01/07/19</p>	<p>NELSON - TASMAN</p> <p>LAND DEVELOPMENT MANUAL</p>	<p>413</p>

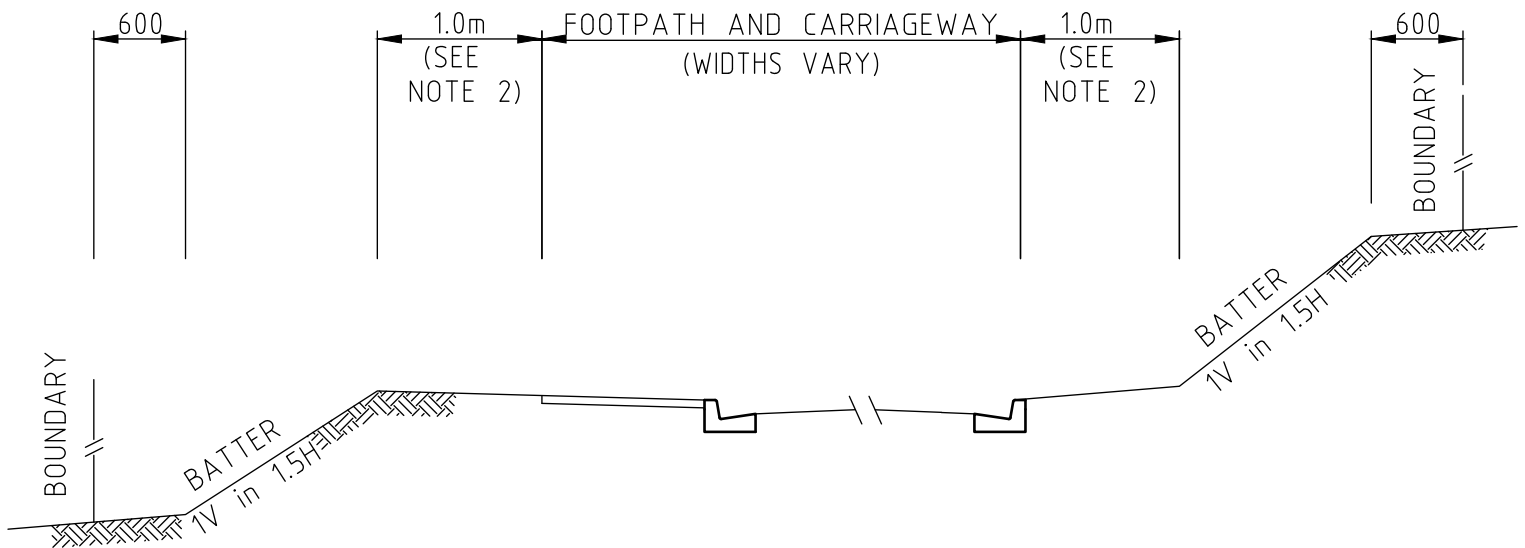

NOTES:

1. RETAINING WALLS WHICH ARE NOT FOR SUPPORTING THE ROAD CARRIGEWAY OR FOOTPATH MUST BE LOCATED OUTSIDE LEGAL ROAD RESERVE
2. THE 1.0m DISTANCE FROM BACK OF FOOTPATH/KERB MAY BE INCREASED WHERE THE AREA IS REQUIRED AS SERVICE STRIPS BY 412 & 413.

<p>NELSON CITY COUNCIL</p> <p><i>[Signature]</i></p> <p>GROUP MANAGER INFRASTRUCTURE, NELSON</p>	<p>TYPICAL CROSS SECTIONS ROADSIDE BATTERS</p>		
<p>TASMAN DISTRICT COUNCIL</p> <p><i>[Signature]</i></p> <p>ENGINEERING SERVICES MANAGER, TASMAN</p>	<p>DATE</p> <p>01/07/19</p>	<p>NELSON - TASMAN LAND DEVELOPMENT MANUAL</p>	<p>414</p>

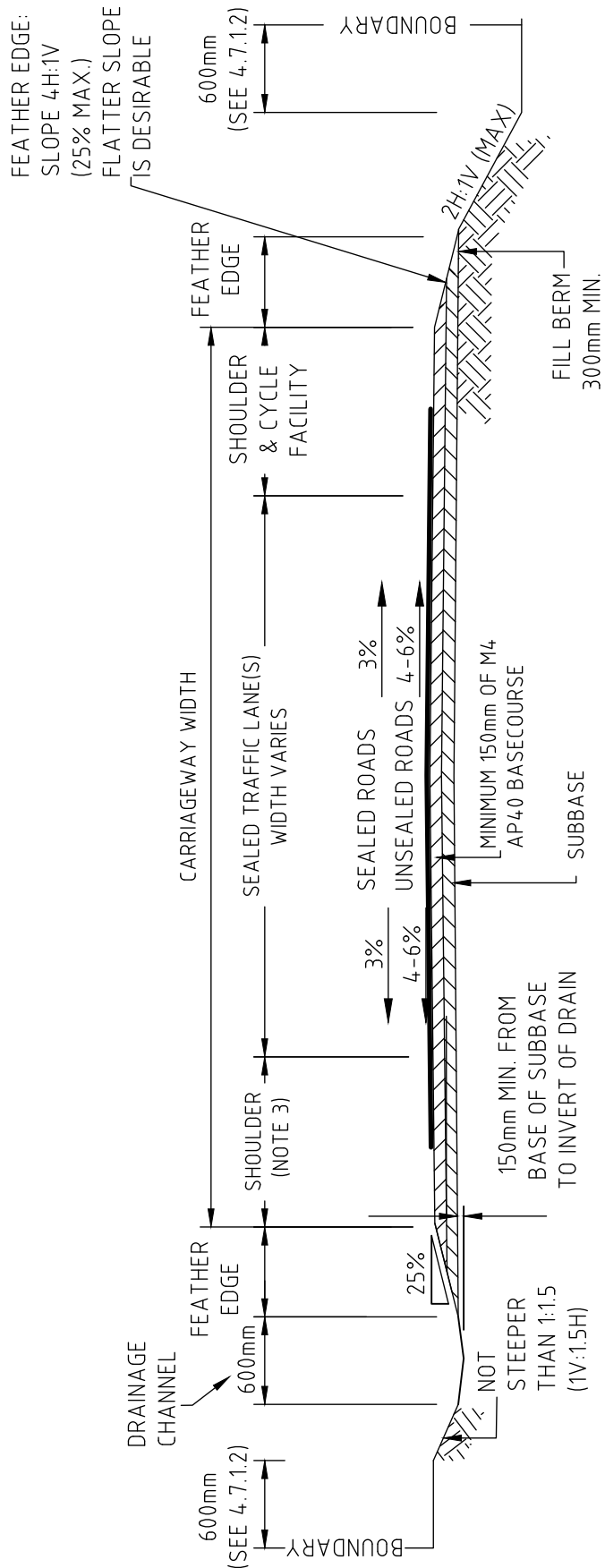

NOTES:

1. DEPTH OF SUBBASE DETERMINED BY INDIVIDUAL PAVEMENT DESIGN FOR EACH STREET/ROAD
2. DRAINAGE CHANNEL SIZE AND SPACING OF STORMWATER CULVERTS, SUBJECT TO SPECIFIC DESIGN
3. FOR SHOULDER & CYCLE FACILITY WIDTHS, SEE CHAPTER 4.6.

NELSON CITY COUNCIL
[Signature]
 GROUP MANAGER INFRASTRUCTURE, NELSON

**TYPICAL CROSS SECTIONS
 RURAL CARRIAGEWAY**

TASMAN DISTRICT COUNCIL
[Signature]
 ENGINEERING SERVICES MANAGER, TASMAN

DATE
 01/07/19

NELSON - TASMAN
 LAND DEVELOPMENT MANUAL

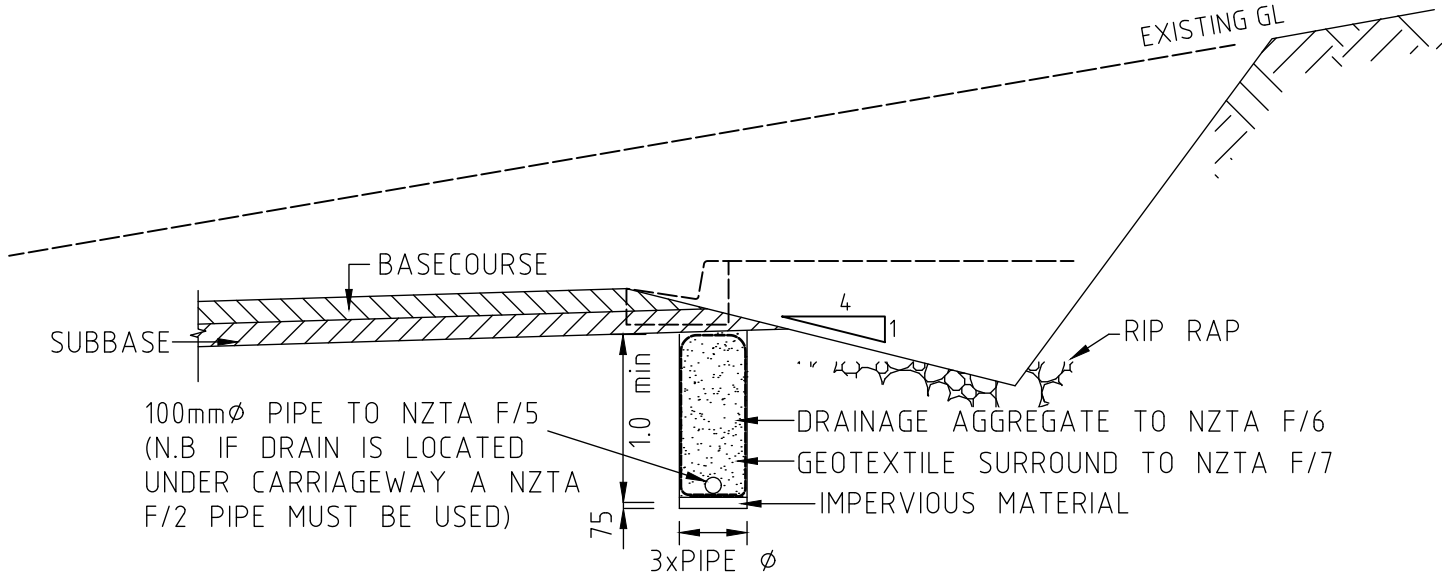

**SUBSOIL DRAIN FILTER DETAIL
(WHEN IN CUT)**

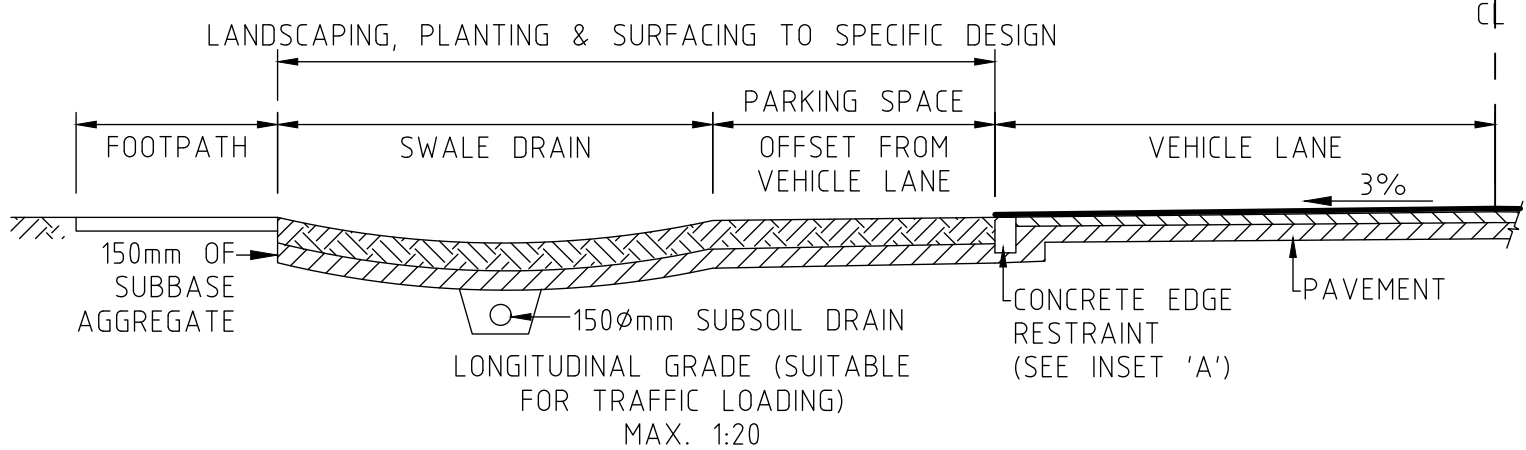

ROADSIDE SWALE DRAINS - SUBJECT TO SPECIFIC DESIGN

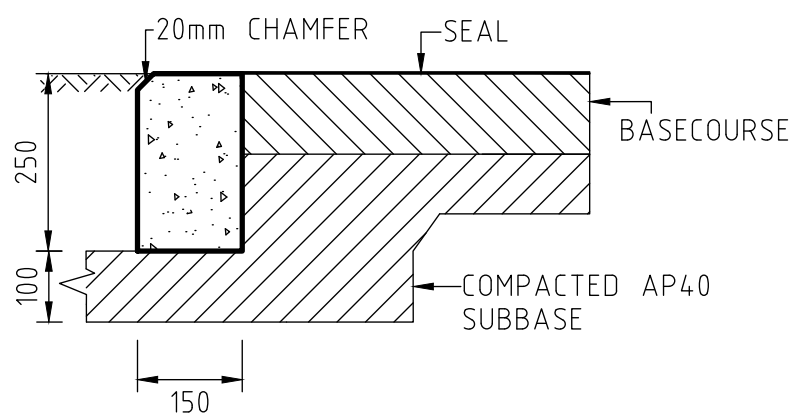

INSET 'A'

<p>NELSON CITY COUNCIL</p> <p><i>[Signature]</i></p> <p>GROUP MANAGER INFRASTRUCTURE, NELSON</p>		<p align="center">TYPICAL DRAINAGE FOR ROADSIDE SWALES & LOW IMPACT STORMWATER</p>	
<p>TASMAN DISTRICT COUNCIL</p> <p><i>[Signature]</i></p> <p>ENGINEERING SERVICES MANAGER, TASMAN</p>		<p>DATE</p> <p>01/07/19</p>	<p align="center">NELSON - TASMAN LAND DEVELOPMENT MANUAL</p>
			<p>416</p>

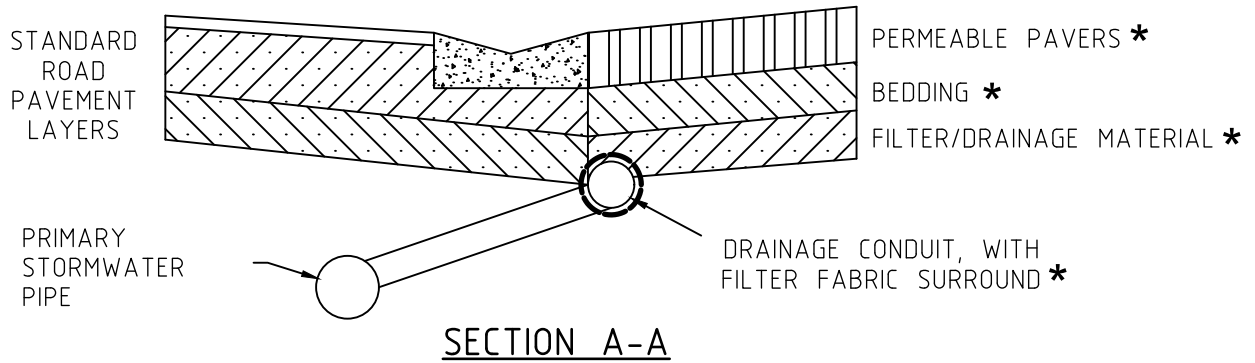

COLLECTION AREA (ON A CASE BY CASE BASIS)
FOR WASTE RECYCLING BINS (COULD BE ON
OTHER SIDE OF ROAD). REFER SECTION 4.6.4.4

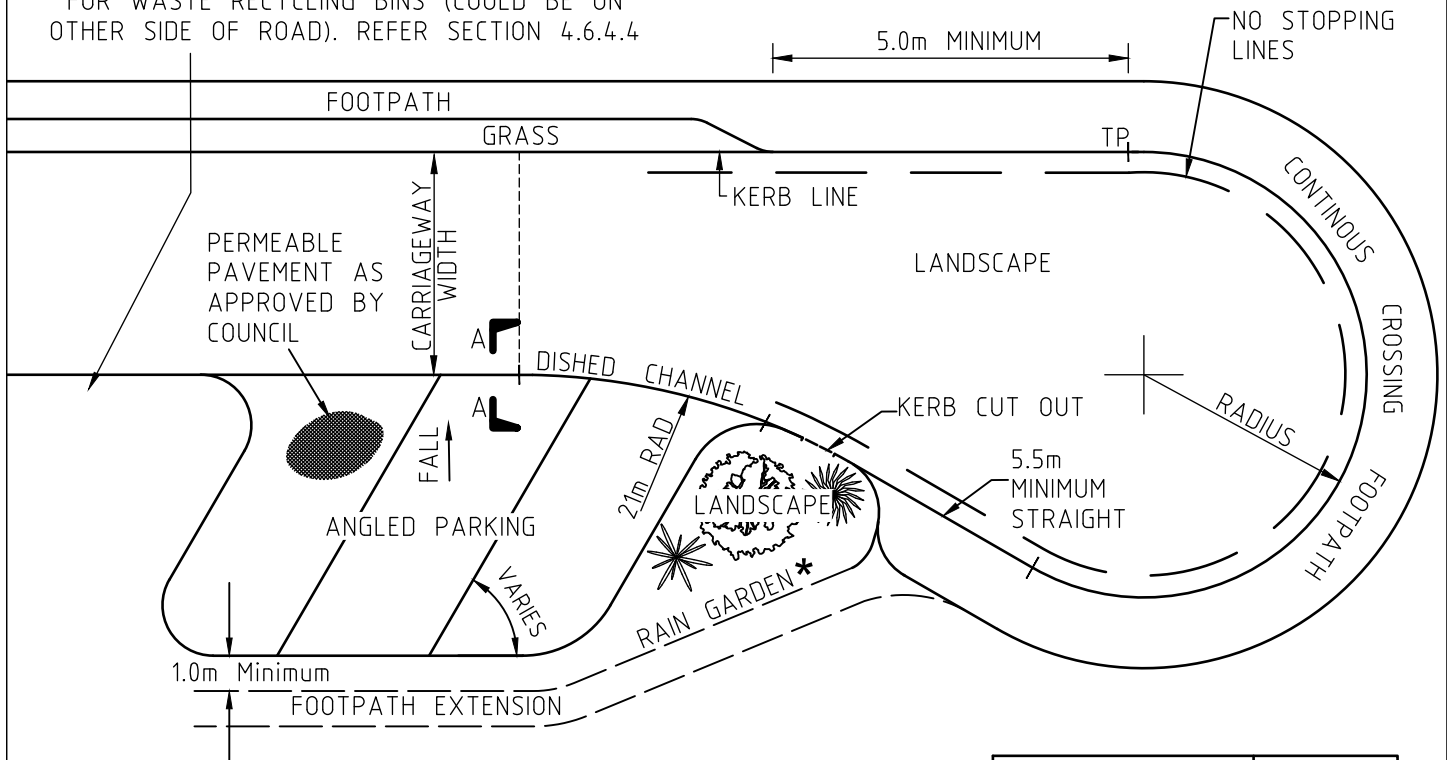

ZONE	RADIUS
RESIDENTIAL	7.0
COMMERCIAL	11.0
INDUSTRIAL	12.0
RURAL LIFESTYLE	8.0

NOTES:

1. NO KERBSIDE PARKING WITHIN THE TURNING CIRCLE
2. FOR RESIDENTIAL DEVELOPMENT ON STEEP HILLSIDE, THE CUL-DE-SAC MAY BE A 'FISH-TAIL' OR 'HAMMERHEAD' DESIGN PROVIDED THE TURNING AREA PERMITS A 90 PERCENTILE 2 AXLE TRUCK TO UNDERTAKE A 3 POINT TURN
3. THIS DRAWING IS AN EXAMPLE CONCEPT ONLY AND THERE ARE OTHER COMPLYING DESIGNS FOR CUL-DE-SAC TURNING HEADS

* (SPECIFIC DESIGN REQUIRED)

<p>NELSON CITY COUNCIL</p> <p>GROUP MANAGER INFRASTRUCTURE, NELSON</p>		<p>CUL-DE-SAC TURNING CIRCLES</p>	
<p>TASMAN DISTRICT COUNCIL</p> <p>ENGINEERING SERVICES MANAGER, TASMAN</p>		<p>DATE</p> <p>01/07/19</p>	<p>NELSON - TASMAN LAND DEVELOPMENT MANUAL</p>
			<p>417</p>

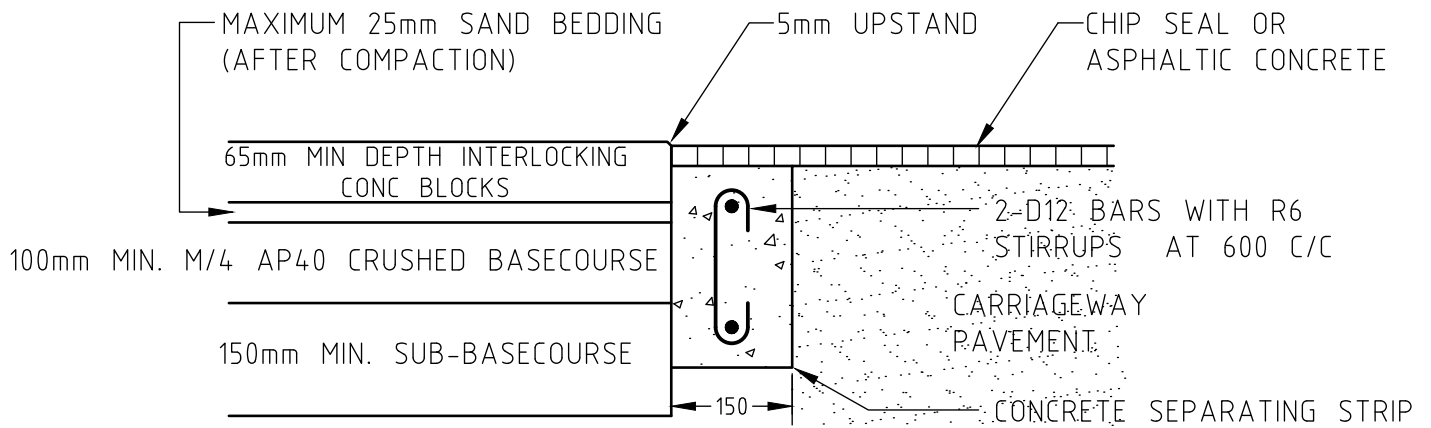

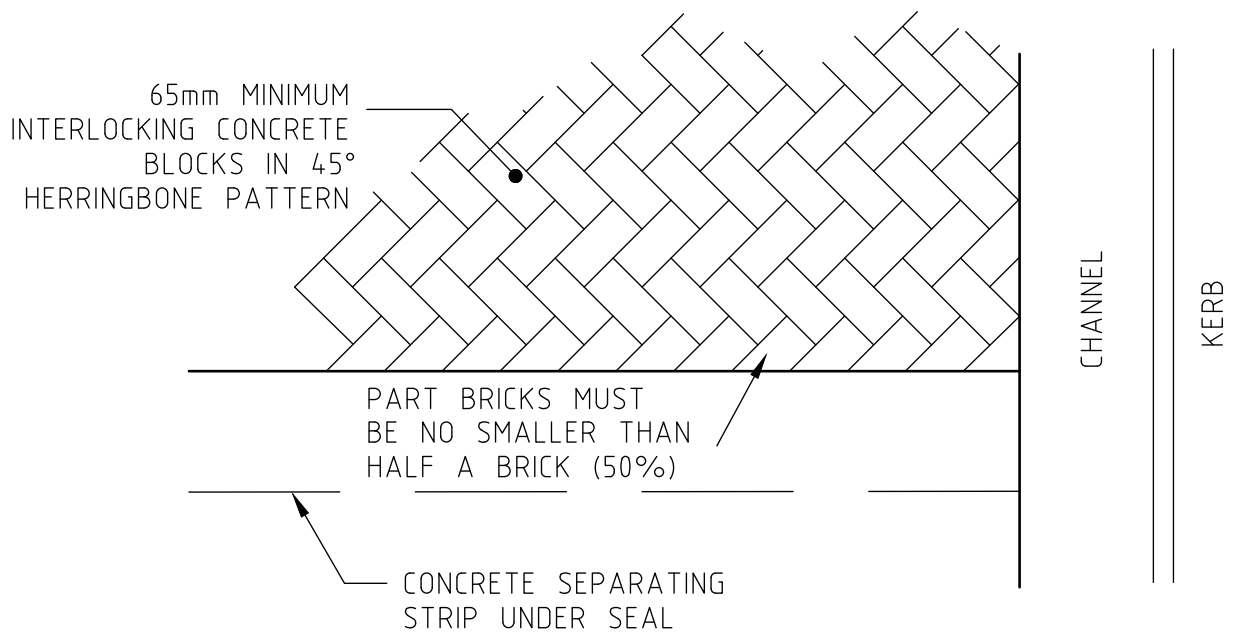

**CARRIAGEWAY THRESHOLDS
(LONGITUDINAL SECTION)**



**CARRIAGEWAY THRESHOLDS
PART PLAN**

NOTES:

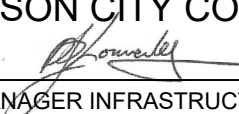
1. CONCRETE BLOCKS SHALL COMPLY WITH NZS 3116: 2002
2. LAYING OF BLOCKS SHALL COMPLY WITH THE CEMENT AND CONCRETE ASSOCIATION OF NZ "INTERLOCKING CONCRETE BLOCK ROAD PAVEMENTS" (SEPT 1988)
3. COLOUR OF BRICKS TO BE GREY AND APPROVED BY COUNCIL
4. IN HIGH TRAFFIC AREAS (COLLECTOR ROAD CATEGORY OR HIGHER) THE BLOCKS SHALL BE LAID ON 150mm DEPTH OF REINFORCED CONCRETE (SUBJECT TO SPECIFIC DESIGN)

NELSON CITY COUNCIL  GROUP MANAGER INFRASTRUCTURE, NELSON		CARRIAGEWAY THRESHOLDS (CONCRETE BLOCKS)	
TASMAN DISTRICT COUNCIL  ENGINEERING SERVICES MANAGER, TASMAN	DATE 01/07/19	NELSON - TASMAN LAND DEVELOPMENT MANUAL	418

NOTES:

1. USE 50mm Sq. WASHER TO TIMBER BOLTS:
Min. TIMBER EDGE DIST.=65mm
Min. EDGE DIST. to STEEL PLATE=18mm
PLATE:
140 x 80 x 6 PLATE
FILLET WELD TO PIPE
ARCSPRAY ALL STEEL
PLACE MALTHOID BETWEEN STEEL AND TIMBER
2. MAXIMUM OPENING SPACE OF THE CHAIN LINK SHALL BE 35mm OR 50mm DIAMETER
3. DESIGN TO DBH (MARCH 12)
SEE DOCUMENT "GUIDANCE ON BARRIER DESIGN"

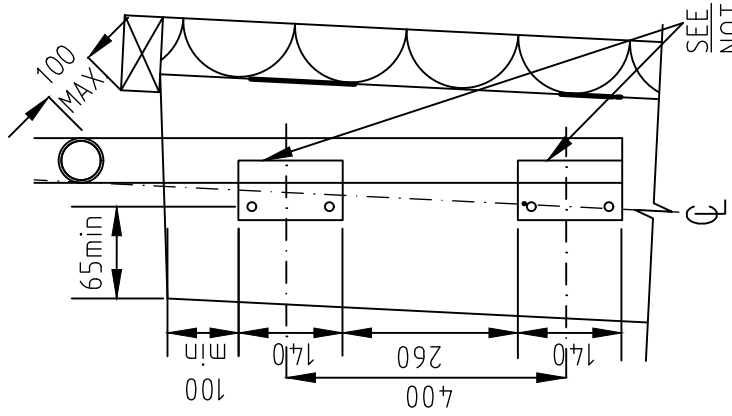

TYPICAL ELEVATION

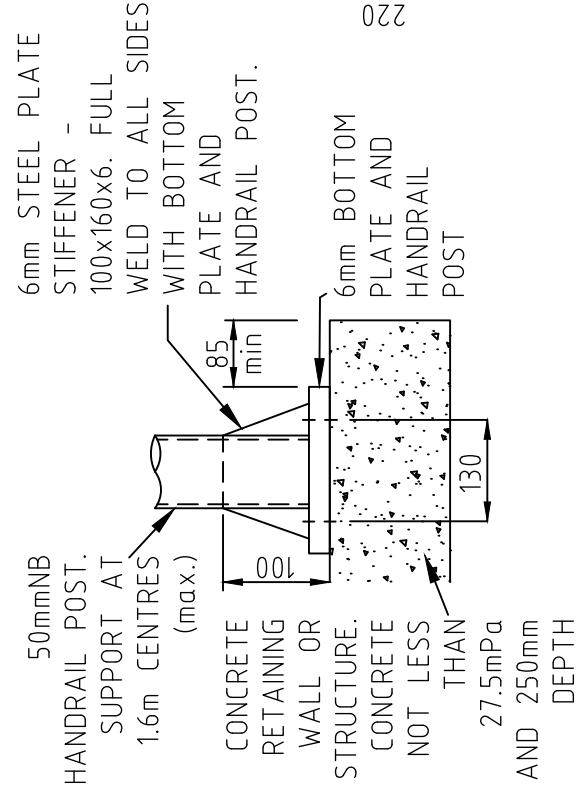

DETAIL (NTS) - FIXING TO CONCRETE SURFACE

FIXING TO TIMBER POLE

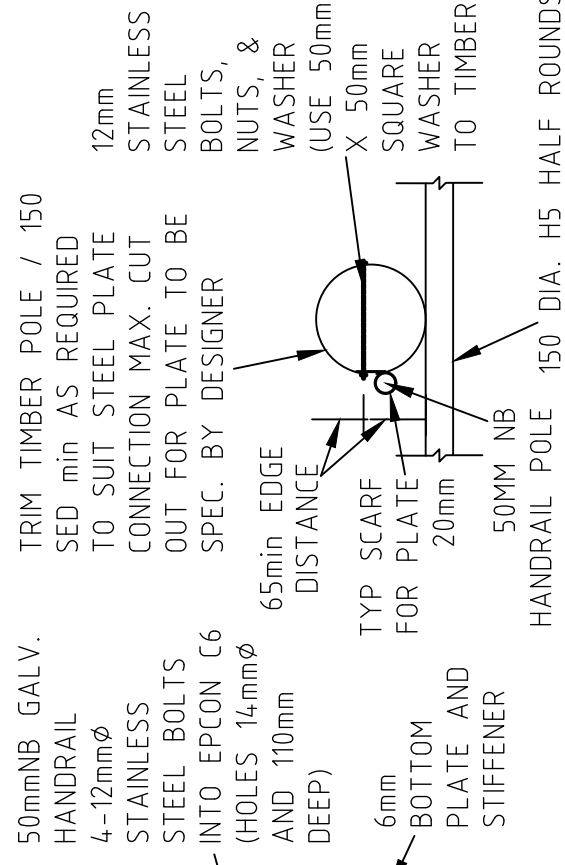

TYPICAL CONNECTION PLAN

NELSON CITY COUNCIL

 GROUP MANAGER INFRASTRUCTURE, NELSON

TASMAN DISTRICT COUNCIL

 ENGINEERING SERVICES MANAGER, TASMAN

DATE
 01/07/19

ALTERNATIVE HANDRAIL CHAIN LINK

NELSON - TASMAN
 LAND DEVELOPMENT MANUAL

NOTES:
ALUMINIUM REFER
TO ALUMINIUM
ALLOY 6063

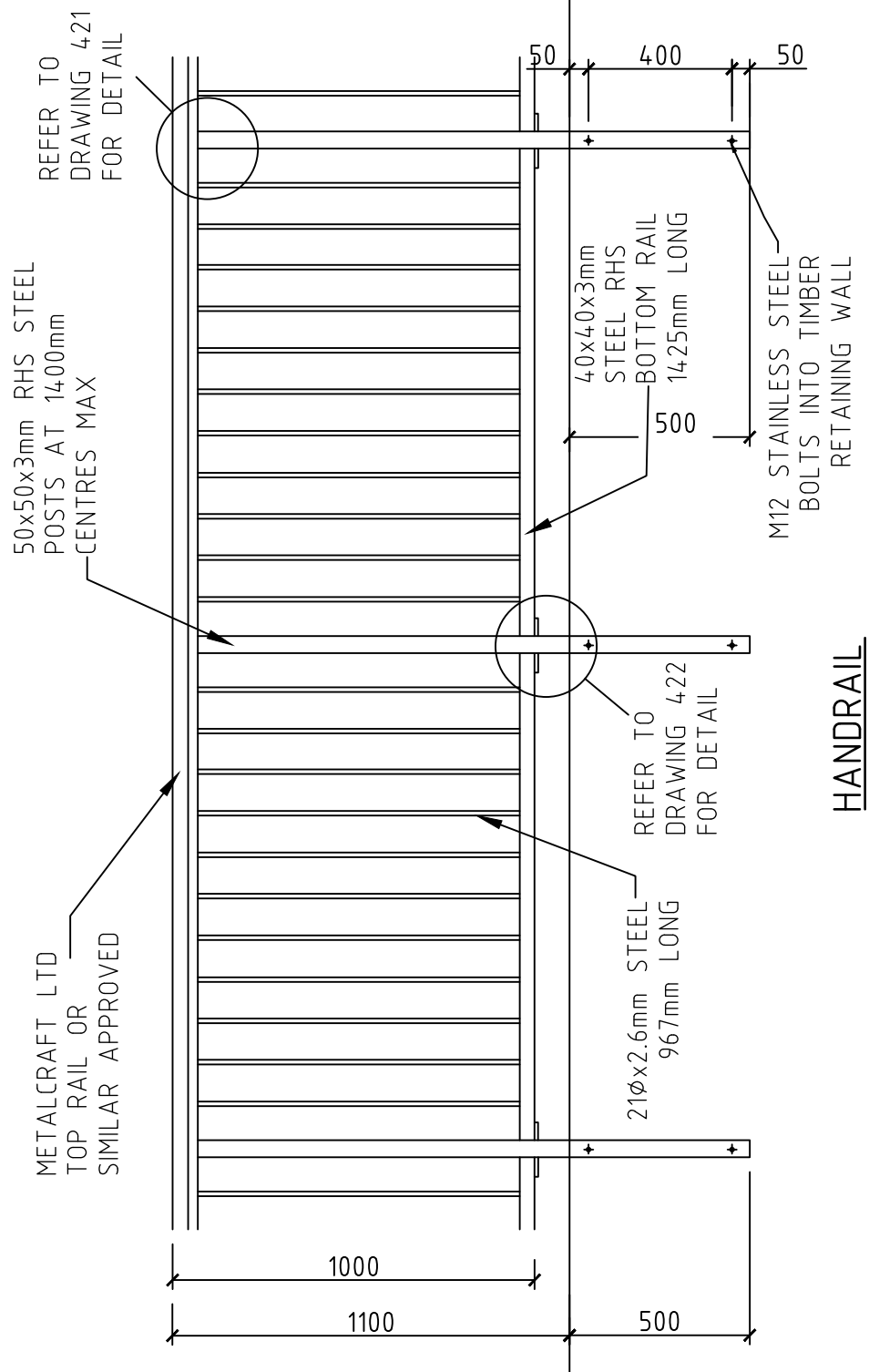
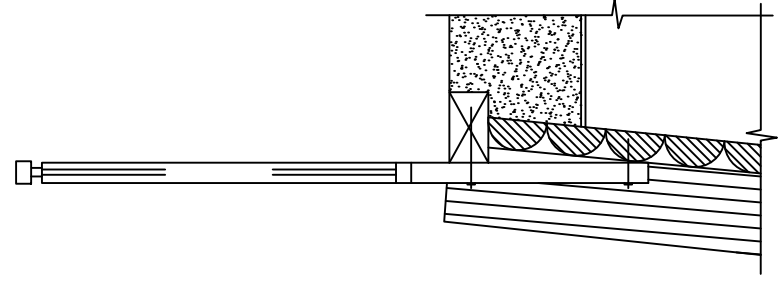

HANDRAIL

- FINISH COATINGS:
- ALUMINIUM - TO BE POWDER COATED IN ORDER TO PROVIDE 15 YEARS WARRANTY
 - STEEL PARTS/SURFACES - TO BE GALVANIZED (HOT DIP) OR ZINC METAL SPRAYED (ARC SPRAY) TO 150 MICROS ZINC COATING THICKNESS AND WITH A COVER COAT OF TWO POT EPOXY OR POWDER COATING. GALVANIZED COATING MUST BE LIGHTLY SANDED BEFORE COVER COATING

NELSON CITY COUNCIL

[Signature]

GROUP MANAGER INFRASTRUCTURE, NELSON

HANDRAIL (1 OF 5)

TASMAN DISTRICT COUNCIL

[Signature]

ENGINEERING SERVICES MANAGER, TASMAN

DATE

01/07/19

NELSON - TASMAN
LAND DEVELOPMENT MANUAL

420

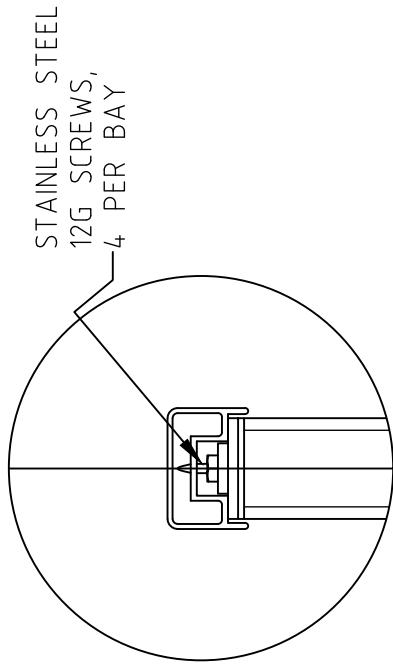

STAINLESS STEEL
12G SCREWS,
4 PER BAY

CROSS SECTION D

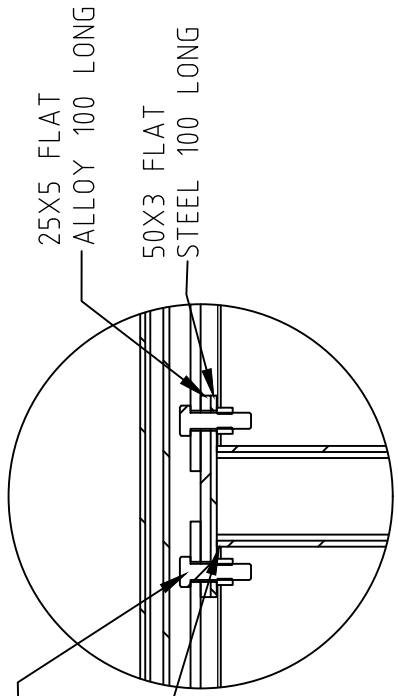

25X5 FLAT
ALLOY 100 LONG

50X3 FLAT
STEEL 100 LONG

2/M8X20 STAINLESS STEEL
THREAD BOLTS THROUGH
CHANNEL INTO AND CAP

FILLET WELD
TO RHS POST

DETAIL C

METALCRAFT LTD TOP RAIL
OR SIMILAR APPROVED

REFER TO
DETAIL C

FILLET WELD
TO RHS POST

STAINLESS STEEL
12G SCREWS,
4 PER BAY

25X5 FLAT STEEL
BEVEL BUTT WELD TO TUBE

21φx2.6mm STEEL
TUBE AT 115mm
CENTRES MAX

50x50x3mm RHS
STEEL POSTS AT
1400mm CENTRES MAX

DETAIL A - TOP

NELSON CITY COUNCIL

GROUP MANAGER INFRASTRUCTURE, NELSON

HANDRAIL DETAIL (2 OF 5)

TASMAN DISTRICT COUNCIL

ENGINEERING SERVICES MANAGER, TASMAN

DATE

01/07/19

NELSON - TASMAN
LAND DEVELOPMENT MANUAL

421

21Ø 2.6mm THICK STEEL TUBE

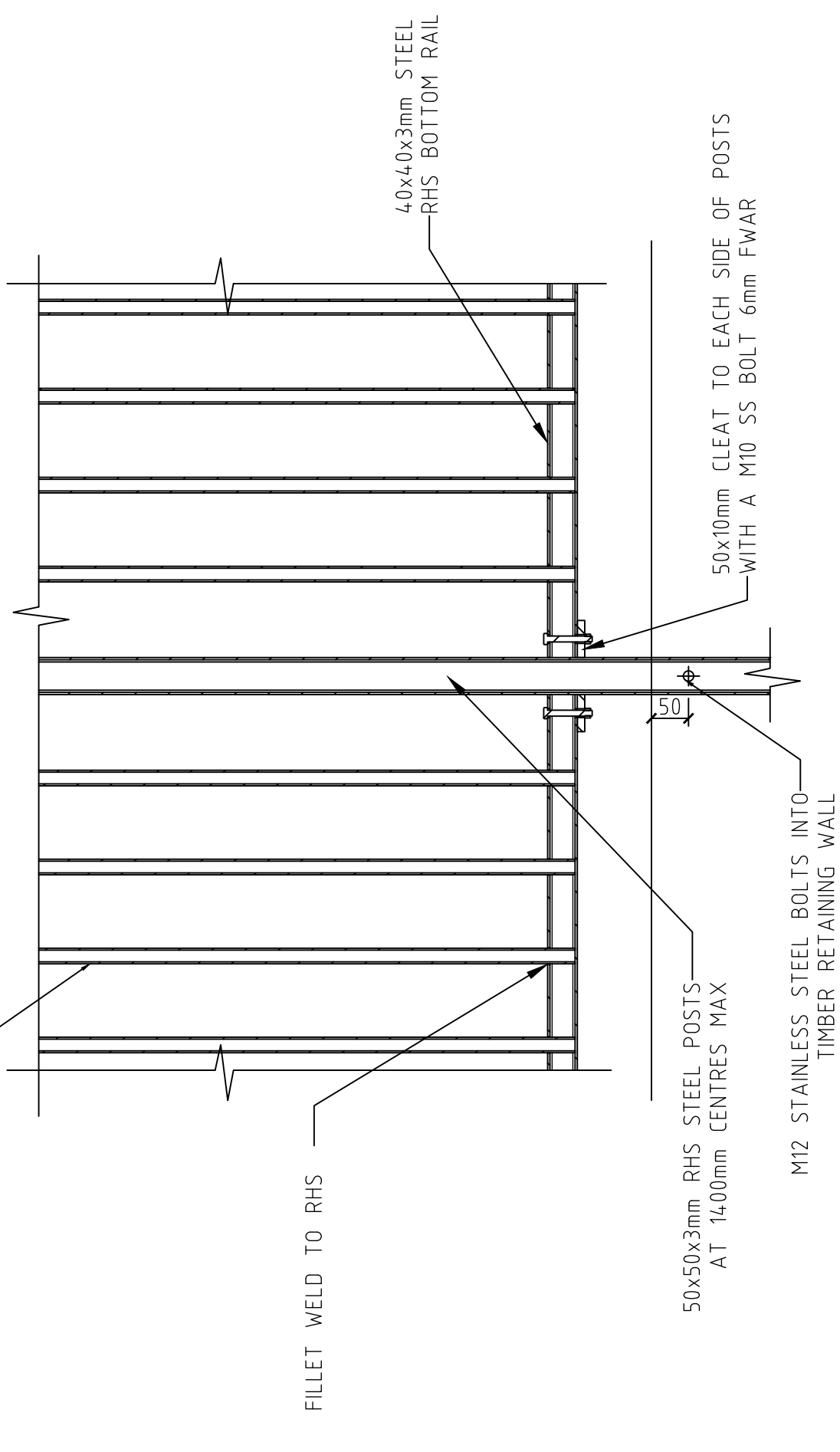

DETAIL B - BOTTOM

NELSON CITY COUNCIL

[Signature]

GROUP MANAGER INFRASTRUCTURE, NELSON

HANDRAIL DETAIL (3 OF 5)

TASMAN DISTRICT COUNCIL

[Signature]

ENGINEERING SERVICES MANAGER, TASMAN

DATE

01/07/19

NELSON - TASMAN
LAND DEVELOPMENT MANUAL

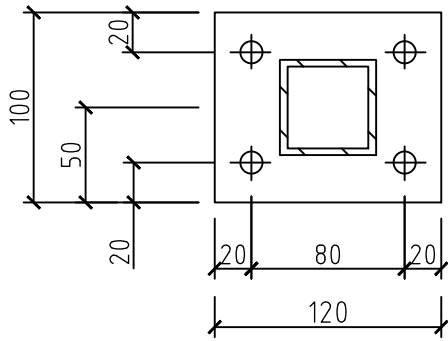

BASE PLATE PLAN

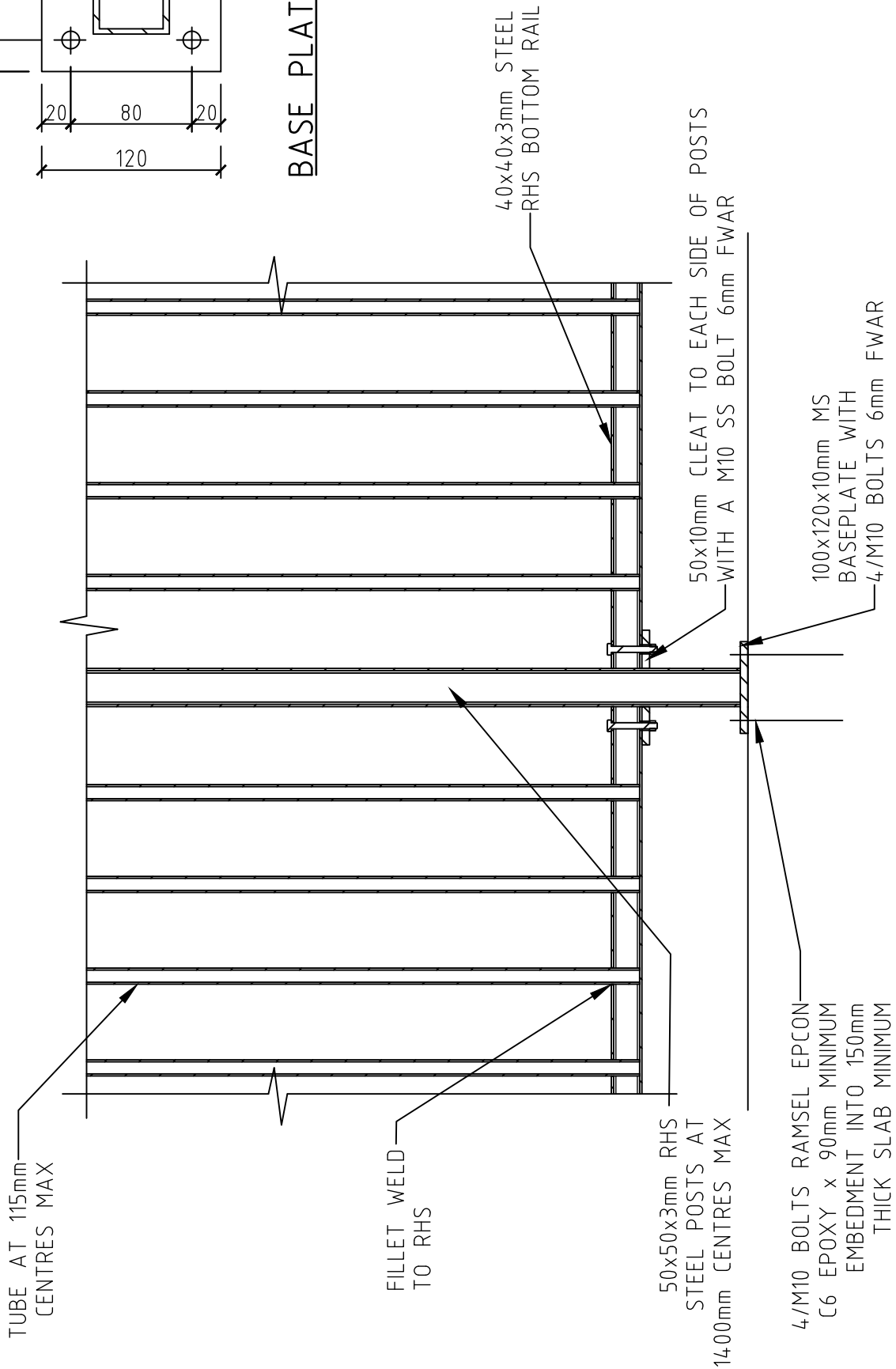

DETAIL B - ALTERNATIVE BOTTOM

NELSON CITY COUNCIL

[Signature]
GROUP MANAGER INFRASTRUCTURE, NELSON

HANDRAIL DETAIL (4 OF 5)

TASMAN DISTRICT COUNCIL

[Signature]
ENGINEERING SERVICES MANAGER, TASMAN

DATE
01/07/19

NELSON - TASMAN
LAND DEVELOPMENT MANUAL

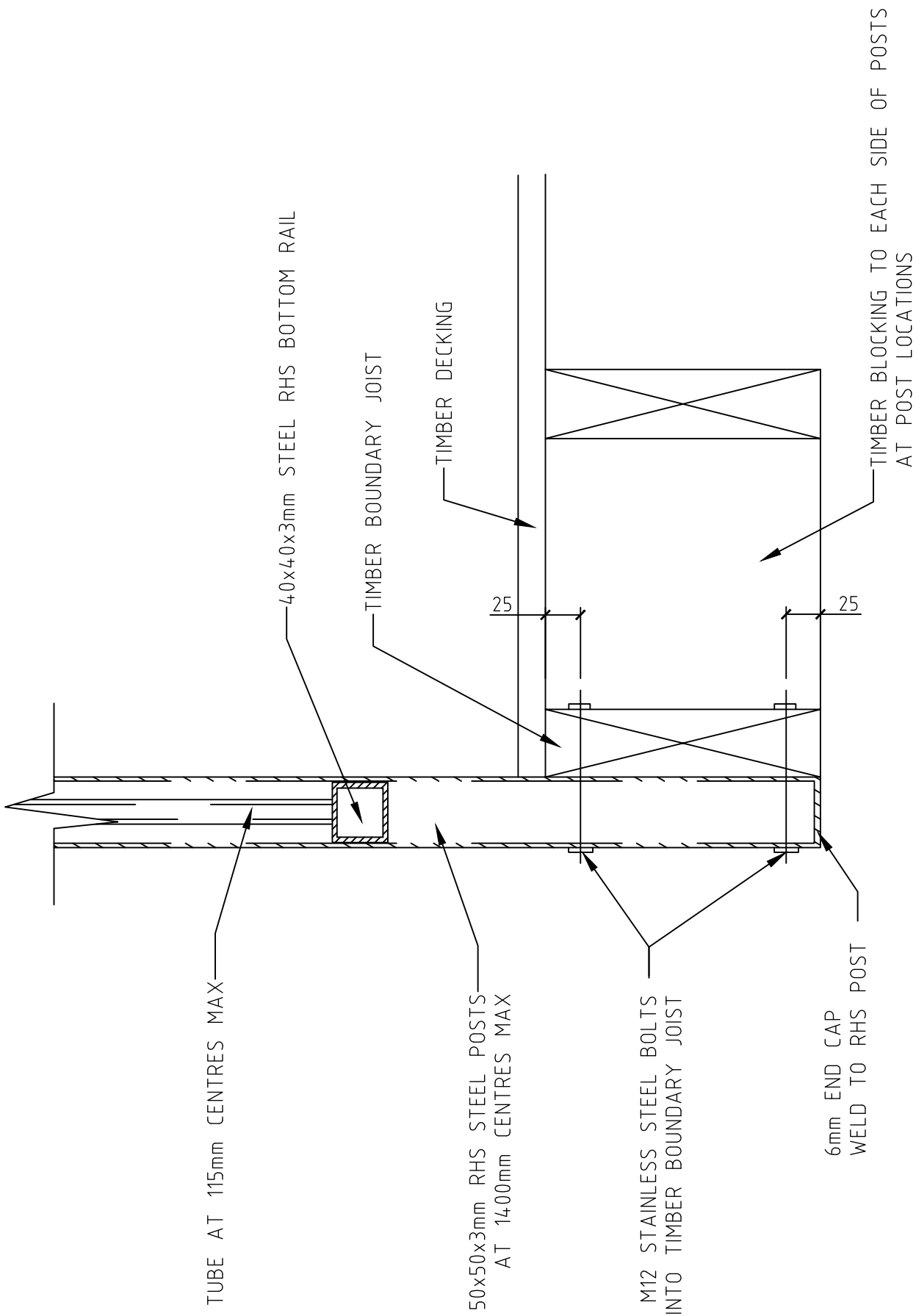

DETAIL B - TIMBER DECK FIXING

NELSON CITY COUNCIL
[Signature]
 GROUP MANAGER INFRASTRUCTURE, NELSON

HANDRAIL DETAIL (5 OF 5)

TASMAN DISTRICT COUNCIL
[Signature]
 ENGINEERING SERVICES MANAGER, TASMAN

DATE
 01/07/19

NELSON - TASMAN
 LAND DEVELOPMENT MANUAL

PLASTER CAP PERMANENTLY AFFIXED WITH DOWEL STARTER AND PAINTED WHITE.

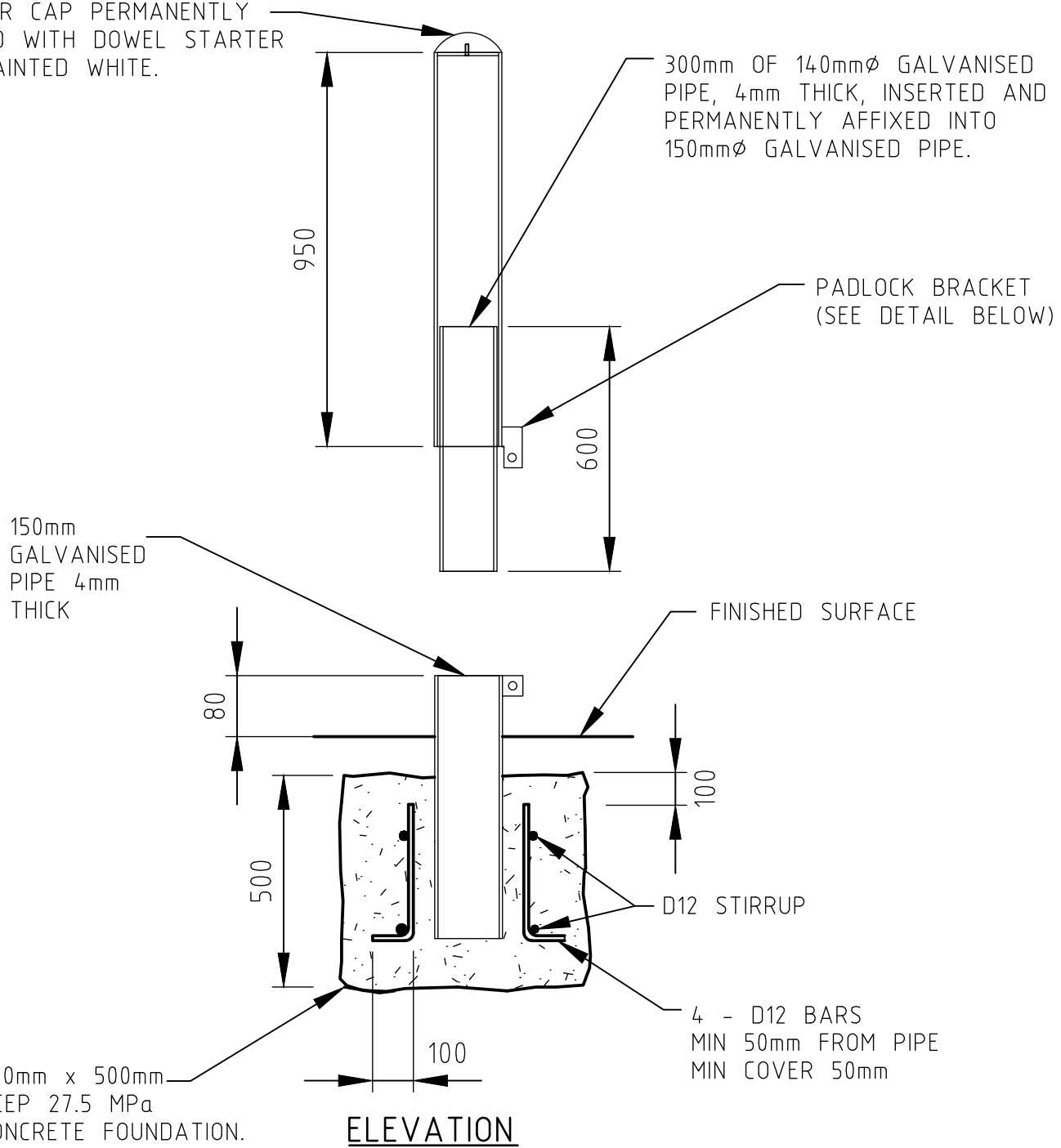

NOTES:

1. ALL STEELWORK SHALL BE PRIMED AND PAINTED WHITE WITH REFLECTIVE STRIPS VISIBLE FROM BOTH WAYS
2. PADLOCK TO BE POSITIONED FACING DIRECTION OF CYCLE TRAFFIC

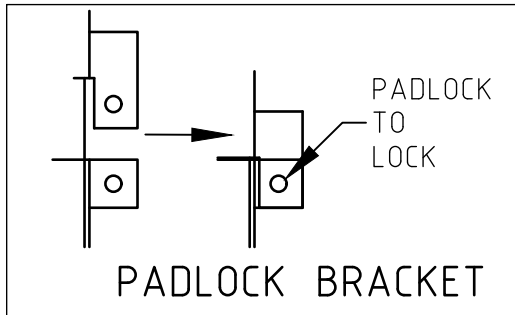

<p>NELSON CITY COUNCIL</p> <p><i>[Signature]</i></p> <p>GROUP MANAGER INFRASTRUCTURE, NELSON</p>		<p>REMOVABLE CYCLE BOLLARD</p>	
<p>TASMAN DISTRICT COUNCIL</p> <p><i>[Signature]</i></p> <p>ENGINEERING SERVICES MANAGER, TASMAN</p>	<p>DATE</p> <p>01/07/19</p>	<p>NELSON - TASMAN</p> <p>LAND DEVELOPMENT MANUAL</p>	<p>425</p>

PLASTER CAP PERMANENTLY
AFFIXED WITH DOWEL STARTER
AND PAINTED WHITE.

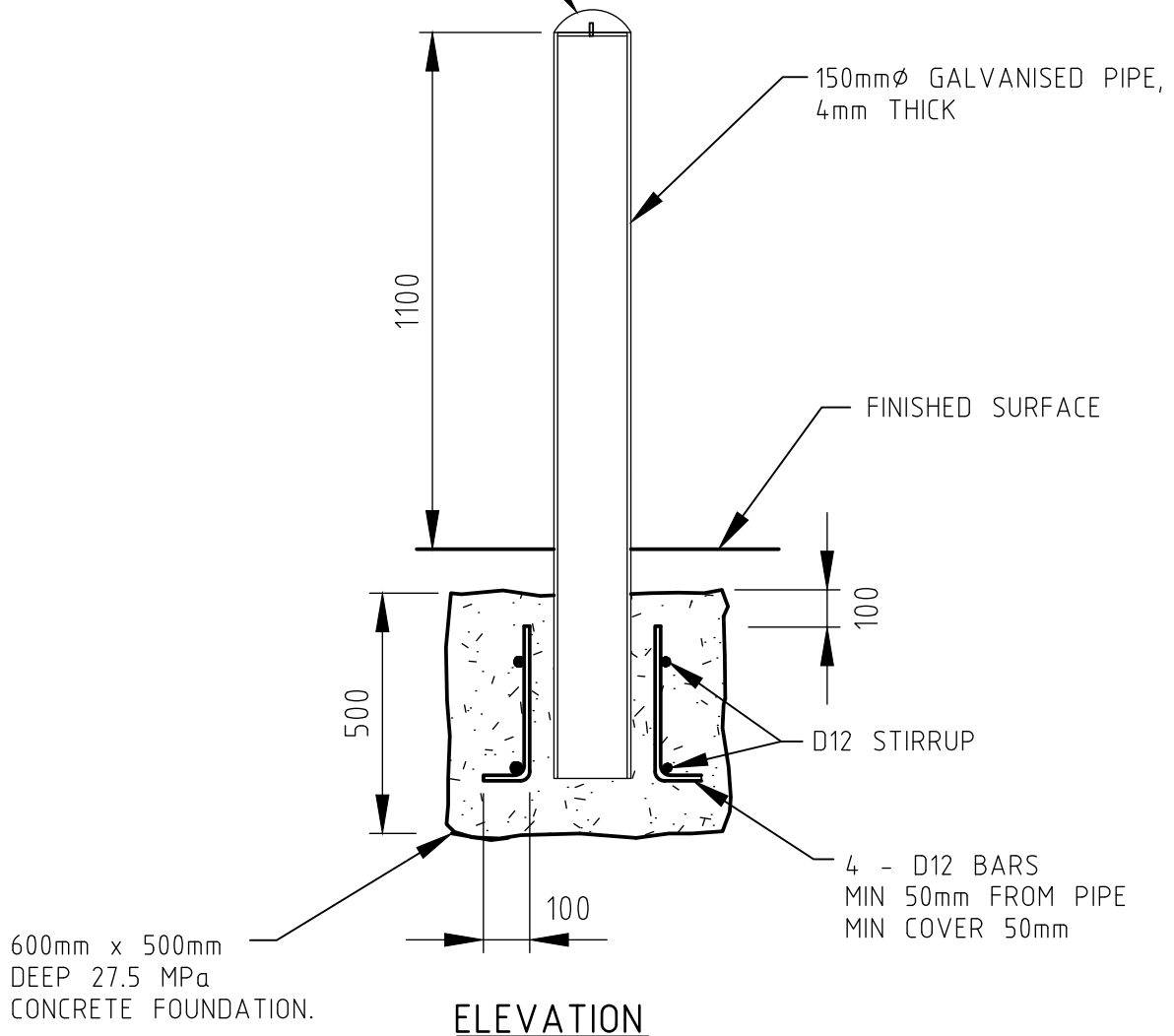

NOTES:

1. ALL STEELWORK SHALL BE PRIMED AND PAINTED WHITE WITH REFLECTIVE STRIPS VISABLE FROM BOTH WAYS

<p>NELSON CITY COUNCIL</p> <p><i>[Signature]</i></p> <p>GROUP MANAGER INFRASTRUCTURE, NELSON</p>	<p>STANDARD CYCLE BOLLARD</p>		
<p>TASMAN DISTRICT COUNCIL</p> <p><i>[Signature]</i></p> <p>ENGINEERING SERVICES MANAGER, TASMAN</p>	<p>DATE</p> <p>01/07/19</p>	<p>NELSON - TASMAN LAND DEVELOPMENT MANUAL</p>	<p>426</p>

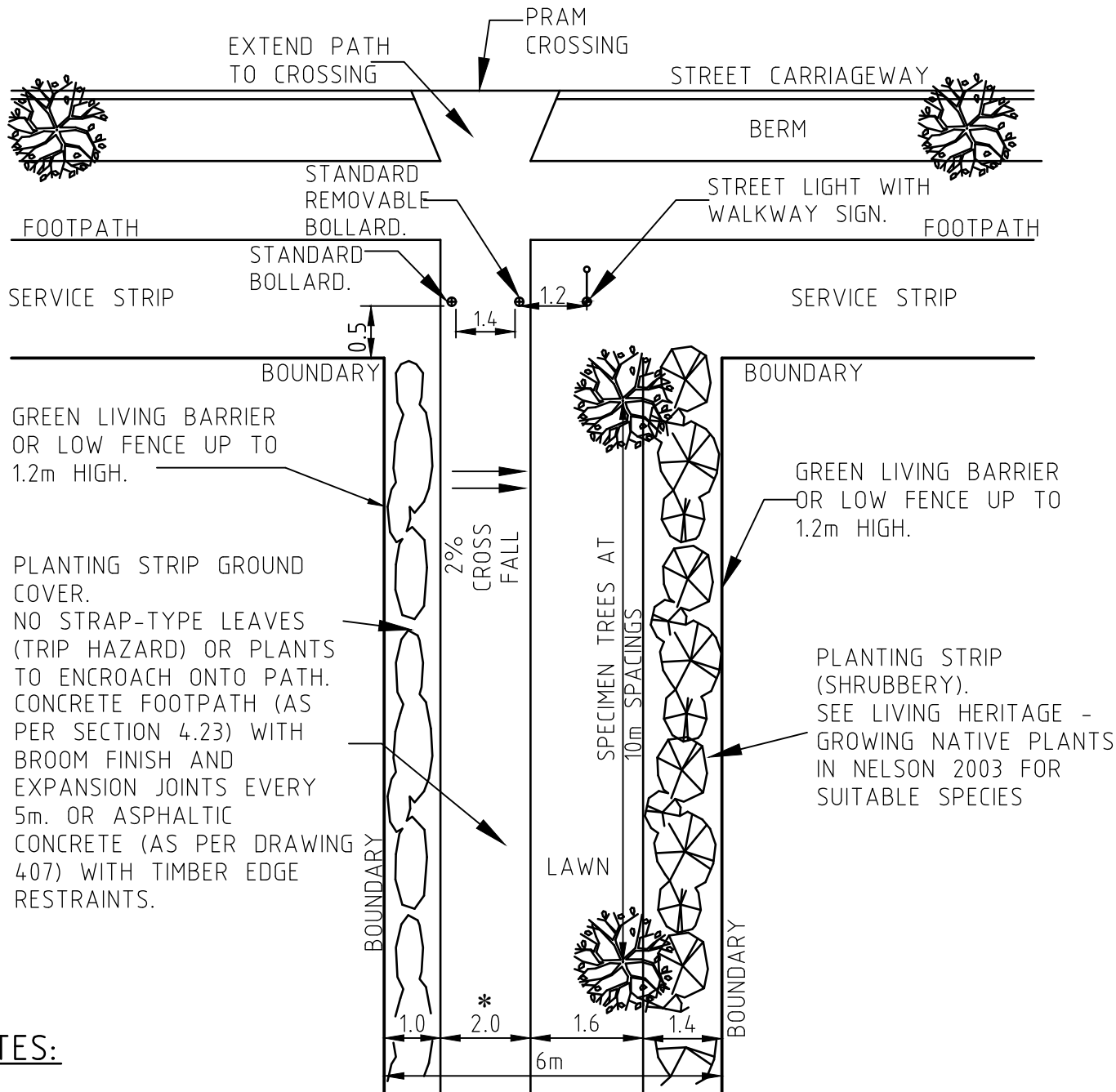

NOTES:

1. * THE PEDESTRIAN/CYCLE ACCESS IS TO BE USED TO LINK A ROAD TO A ROAD OR ROAD TO RESERVE. FOR SHARED ACCESSWAYS THAT ARE ON A MAIN ROUTE & WILL HAVE A HIGH USE, THEN THE SEALED PATHWAY SHALL BE 3.0m & SUBJECT TO SPECIFIC DESIGN.
2. WITH WALKWAYS ORIENTED EAST/WEST PLANT TREES ON THE NORTHERN SIDE OF THE FOOTPATH.
3. IF STEPS ARE REQUIRED FOR GRADES GREATER THAN 1:5 THEN BALUSTRADES SHALL BE PROVIDED TO ONE SIDE. ALSO, A HALF-ROUND OPEN CONCRETE CHANNEL SHALL BE FORMED ADJACENT THE STEPS TO ASSIST CYCLE MOVEMENT,
4. STEPS SHALL BE NO NARROWER THAN 300mm TREAD WITH 150-180 RISER. A LANDING SHALL BE PROVIDED EVERY 20 STEPS. NO LESS THAN 3 STEPS SHALL BE PROVIDED IN ANY ONE AREA.
5. FOR BOLLARD DETAILS SEE DRAWINGS 425 & 426
6. STORMWATER CONTROL IN THE FORM OF KERB, CHANNEL AND SUMPS SHALL BE PROVIDED. THIS SHALL BE DETAILED ON THE DESIGN ENGINEERING PLANS AT THE TIME OF APPROVAL.

<p>NELSON CITY COUNCIL</p> <p><i>[Signature]</i></p> <p>GROUP MANAGER INFRASTRUCTURE, NELSON</p>	<p>PUBLIC ACCESSWAY</p>
---	--------------------------------

<p>TASMAN DISTRICT COUNCIL</p> <p><i>[Signature]</i></p> <p>ENGINEERING SERVICES MANAGER, TASMAN</p>	<p>DATE</p> <p>01/07/19</p>	<p>NELSON - TASMAN</p> <p>LAND DEVELOPMENT MANUAL</p>	<p>427</p>
---	-----------------------------	---	-------------------

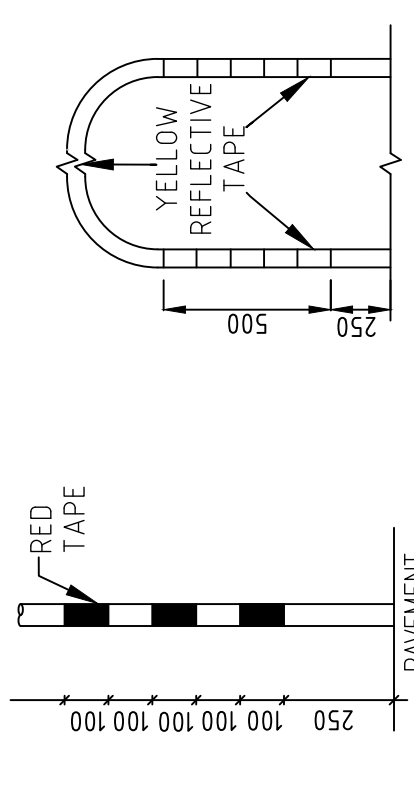

NOTE: USE THIS DETAIL WHEN RAILS ARE WITHIN CARRIAGEWAY AREA AND SEEN BY MOTOR VEHICLES.

NOTE: USE THIS DETAIL WHEN RAILS ARE OUTSIDE CARRIAGEWAY AREA AND SEEN BY CYCLISTS.

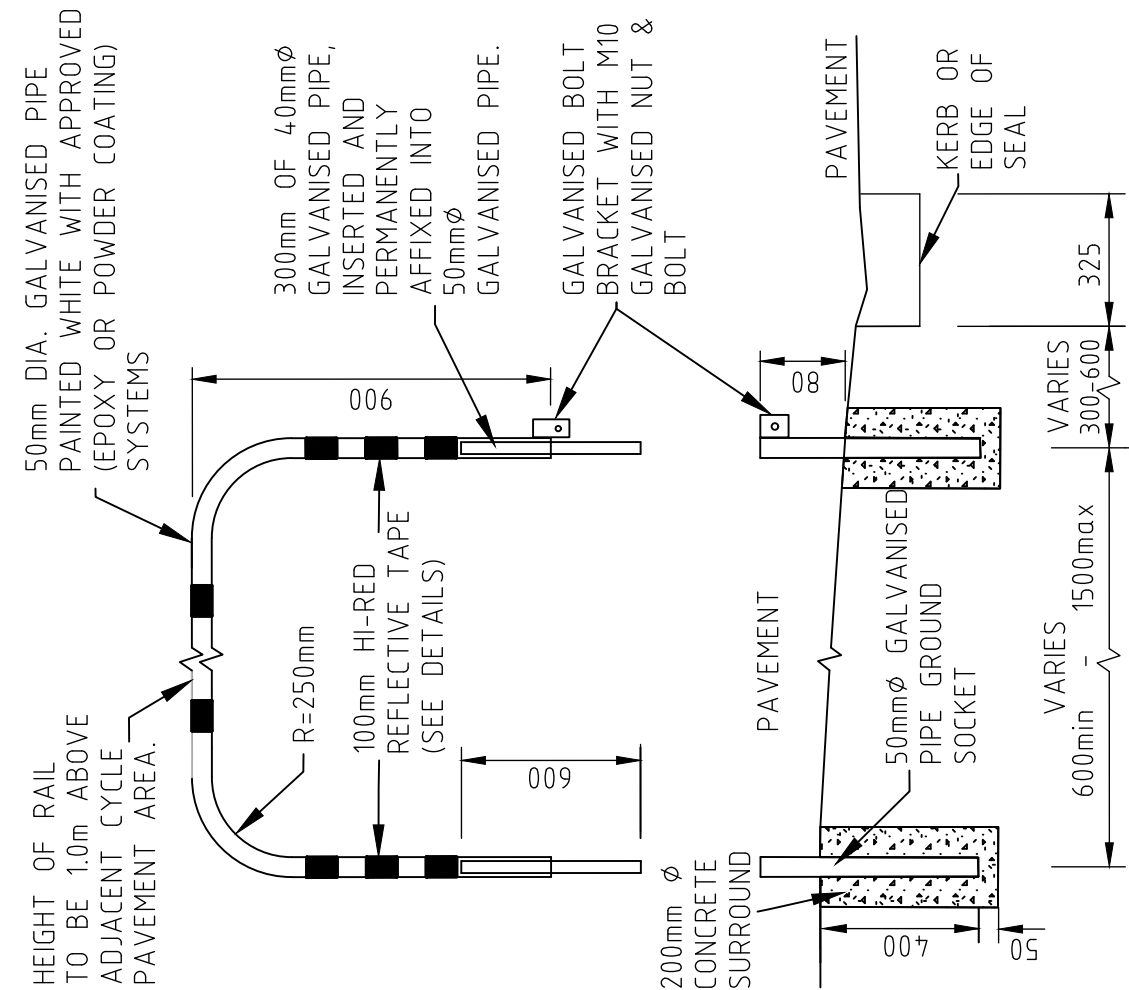

HOLDING RAIL ELEVATION

- NOTES:**
- RAIL TO BE PLACED AT EDGE OF CYCLEWAY PAVEMENT OR 300mm FROM EDGE OF PEDESTRIAN REFUGES.
 - TOP RAIL SHALL BE 1.0m ABOVE ADJACENT PAVEMENT

DETAILS

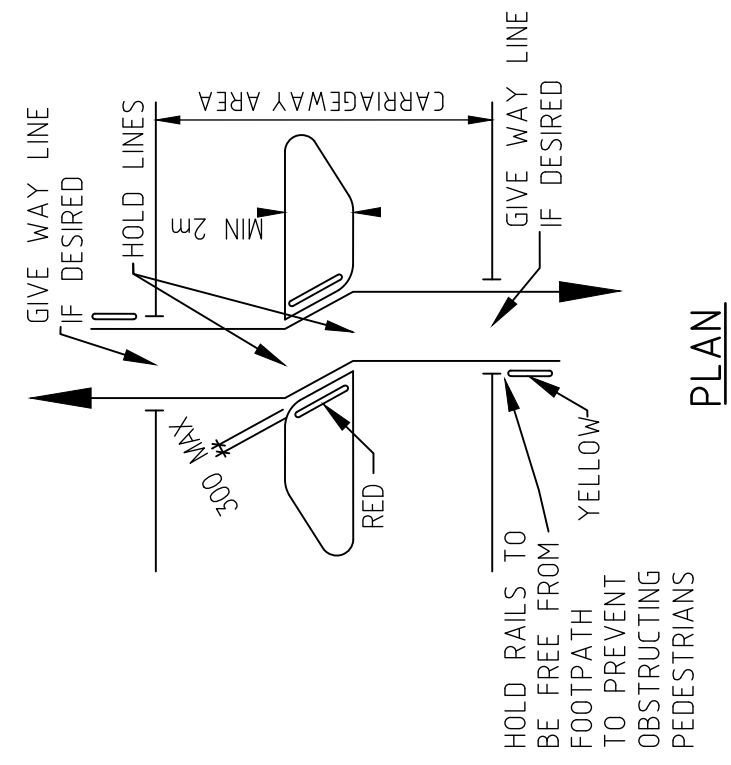

PLAN

NELSON CITY COUNCIL
[Signature]
 GROUP MANAGER INFRASTRUCTURE, NELSON

TASMAN DISTRICT COUNCIL
[Signature]
 ENGINEERING SERVICES MANAGER, TASMAN

DATE
 01/07/19

CYCLE HOLDING RAIL

NELSON - TASMAN
 LAND DEVELOPMENT MANUAL

NOTES:

SELECTED 1.8m+ TREE GROWN IN A PB90 OR 60 LITRE BAG AND TRAINED AS A STREET TREE. PRUNE TO SHAPE AFTER PLANTING. REMOVE DAMAGED BRANCHES AS REQUIRED.

FOR EXTRA INITIAL SUPPORT THE TREE SHOULD BE TIED IN TWO OPPOSITE DIRECTIONS WITH A SUITABLE LENGTH OF APPROVED TREE TIE.

APPROVED NCC/TDC TREE GUARD PAINTED IN GLOSS BLACK ENAMEL (POWDER COAT).

TREE GUARD BOLTED TO TREE GRATE. DRILL AND TAP GRATE IN WORKSHOP. ENSURE TREE GUARD IS PERPENDICULAR.

2x4 LITRE/HOUR DRIPPER IRRIGATION IF POSSIBLE.

APPROX 1200

KERB

500

FOOTPATH

500

NCC/TDC APPROVED CAST IRON TREE GRATE SUPPORTED BY FRAME AND/OR CONCRETE SURROUND

150x150 CONCRETE 27.5mPa SURROUND REINFORCED WITH D12 BAR.

PURPOSE MADE PLASTIC ROOT DIRECTOR. MINIMUM 1.0m DIAMETER x 0.75m DEPTH

PURPOSE MADE PLASTIC ROOT CELLS LOADED WITH TOPSOIL. PLACE POROUS GEOTEXTILE ABOVE ROOT CELLS

50/50 MIX OF COMPOST AND GOOD CLEAN TOPSOIL. EVENLY COMPACTED AROUND ROOTS OR ROOT BALL.

EXCAVATE A ROOT WELL A MINIMUM 500mm BELOW THE ROOT BALL OR DEEPER DEPENDING ON THE HEIGHT OF THE WINTER WATER TABLE. ENSURE THE BOTTOM AND SIDES ARE FREE DRAINING. BACKFILL WITH TOP QUALITY TOPSOIL.

1. TOTAL VOLUME OF ROOT CELLS PLUS ROOT WELL SHALL BE A MINIMUM OF 4m³. UP TO 10m³ MAY BE REQUIRED FOR LARGE TREES TO ENSURE TREE CAN MATURE TO 100 YEAR LIFE MINIMUM.
2. DO NOT APPLY SLOW RELEASE HERBICIDE GRANULES IN THE VICINITY OF STREET TREES.
3. REMOVE BOTH GRATES AND GUARD AFTER 5 YEARS FROM PLANTING.
4. TOP UP TO PATH LEVEL WITH PEA METAL OR SIMILAR.
5. IF IRRIGATION IS NOT AVAILABLE, A 50mm GAP SHOULD BE LEFT BETWEEN THE GRATE AND THE SOIL TO ALLOW A 'WELL' FOR TREE WATERING. THE GRATES WILL BE SUPPORTED BY THE CONCRETE PLANTER.
6. TREE TO BE PLANTED BY EXPERIENCED STAFF. PRUNE ANY DAMAGED ROOTS, AND APPLY SLOW RELEASE FERTILISER.

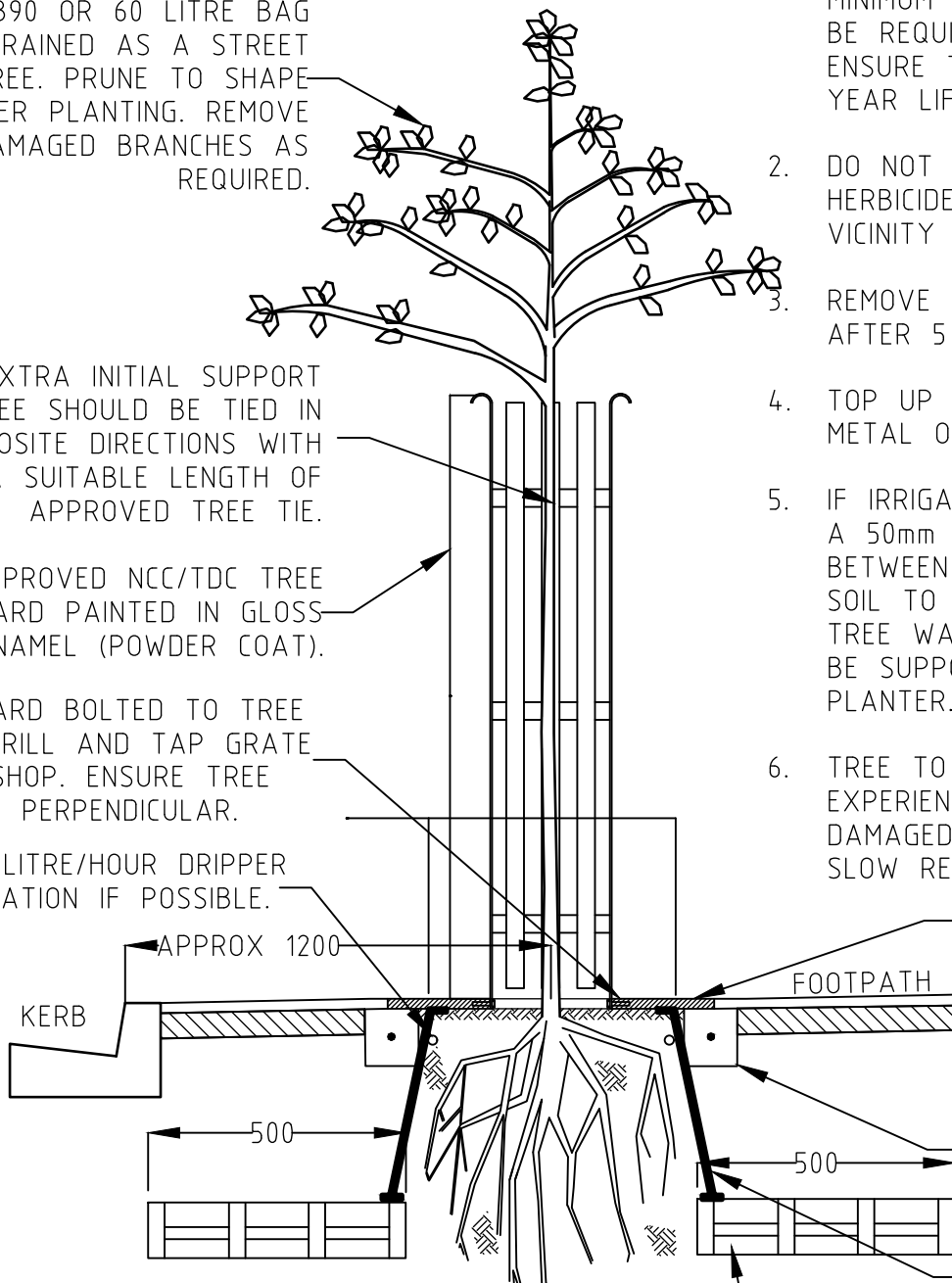

NELSON CITY COUNCIL

GROUP MANAGER INFRASTRUCTURE, NELSON

TASMAN DISTRICT COUNCIL

ENGINEERING SERVICES MANAGER, TASMAN

STREET TREE PLANTER IN FOOTPATH OR PEDESTRIAN AREAS

DATE
01/07/19

NELSON - TASMAN
LAND DEVELOPMENT MANUAL

429

SELECTED 1.8m+ TREE GROWN IN A PB90 OR 60 LITRE BAG AND TRAINED AS A STREET TREE. PRUNE TO SHAPE AFTER PLANTING. REMOVE DAMAGED BRANCHES AS REQUIRED.

NOTES:

1. TOTAL VOLUME OF ROOT WELL SHALL BE A MINIMUM OF 4m³ & ALLOW TREE TO MATURE TO 100 YEAR LIFE.
2. DO NOT APPLY SLOW RELEASE HERBICIDE GRANULES IN THE VICINITY OF STREET TREES
3. TREE TO BE PLANTED BY EXPERIENCED STAFF. PRUNE ANY DAMAGED ROOTS, AND APPLY SLOW RELEASE FERTILISER
4. 50/50 MIX OF COMPOST AND GOOD CLEAN TOPSOIL. EVENLY COMPACTED AROUND ROOTS OR ROOT BALL

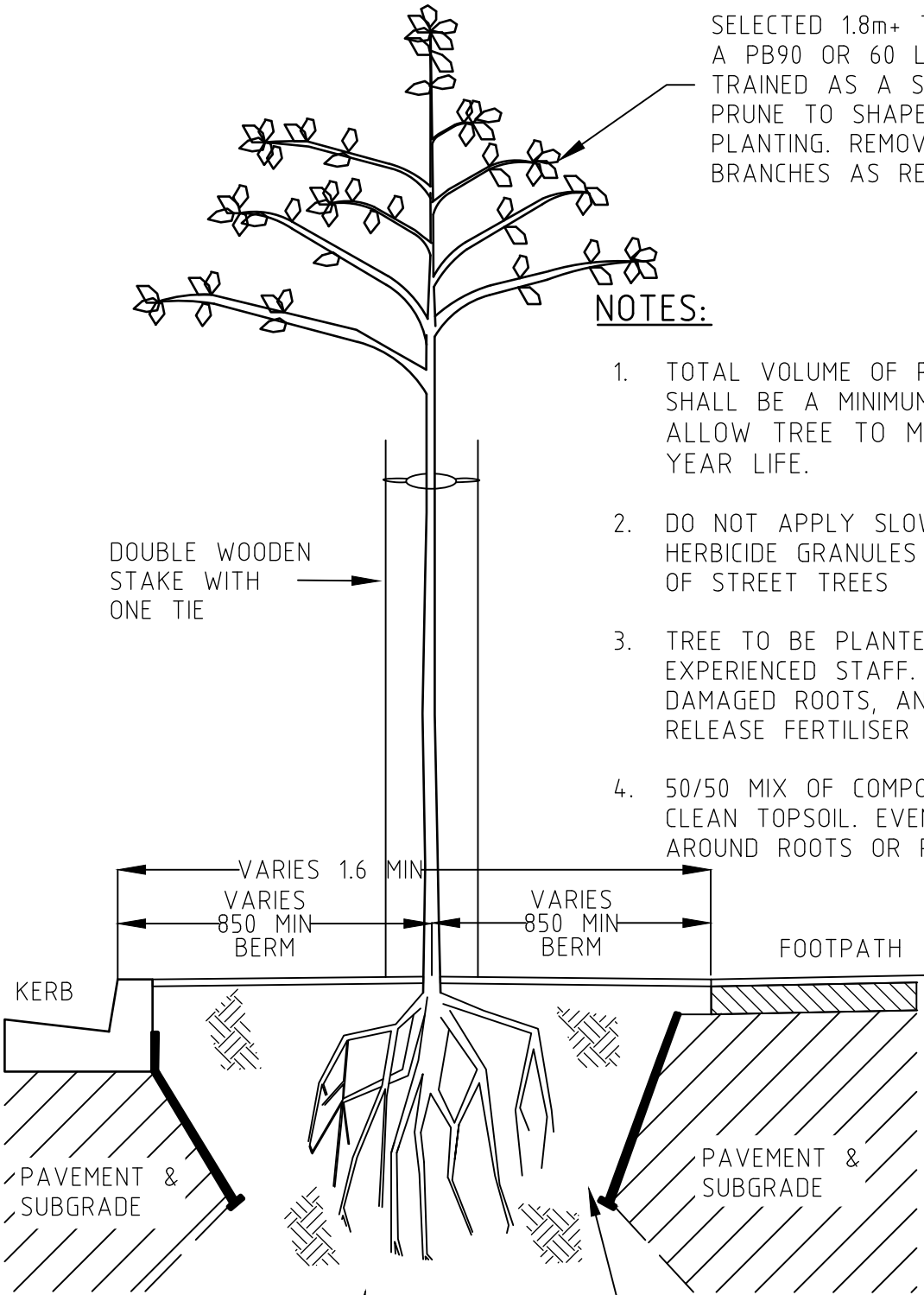

EXCAVATE A ROOT WELL A MINIMUM OF 500mm BELOW THE ROOT BALL OR DEEPER DEPENDING ON THE HEIGHT OF THE WINTER WATER TABLE. ENSURE THE BOTTOM AND SIDES ARE FREE DRAINING. BACKFILL WITH TOP QUALITY TOPSOIL. PLANTED AREA TO BE 3.0m MIN LONGITUDINALLY ALONG KERB ETC.

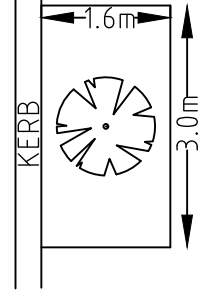

PURPOSE MADE PLASTIC ROOT DIRECTOR WHERE ADJACENT TO KERB, FOOTPATHS, or PAVED SURFACES. MINIMUM 1.0m DIAMETER X 0.75m DEPTH

TOP VIEW

NELSON CITY COUNCIL

 GROUP MANAGER INFRASTRUCTURE, NELSON

**STREET TREE PLANTER
 IN BERM**

TASMAN DISTRICT COUNCIL

 ENGINEERING SERVICES MANAGER, TASMAN

DATE
 01/07/19

NELSON - TASMAN
 LAND DEVELOPMENT MANUAL